

Introduction

Congratulations on your new 3G/UMTS SX633A phone.

About This User Guide

This user guide is carefully designed to help you learn about your phone's features and operations quickly and effectively.

NOTICE

- We strongly recommend that you keep separate permanent written records of all important data. Data may be lost or altered in virtually any electronic memory product under certain circumstances. Therefore, we assume no responsibility for data lost or otherwise rendered unusable, whether as a result of improper use, repairs, defects, battery replacement, use after the specified battery life has expired or any other cause.
- We assume no responsibility, directly or indirectly, for financial losses or claims from third parties resulting from the use of this product and any of its functions, such as stolen credit card numbers, the loss or alteration of stored data, etc.
- All company and/or product names are trademarks and/or registered trademarks of their respective holders.

- Screen layout may differ from that illustrated in this user guide.
The information described in this user guide is subject to change without notice.
- All the functions described in this user guide may not be supported by all networks.
- We assume no responsibility for downloaded contents, information, etc. from the network.
- Occasionally, a few black or bright pixels may appear on the screen. Please note that this will not have any impact on any of the features or on performance.

Copyright

According to copyright laws, the reproduction, alteration and use of material which is protected by copyright (music, pictures, etc.) is only permitted for personal or private use. If the user is not in possession of more extensive copyright or has not received the explicit permission from the copyright owner to reproduce, alter or use a copy which has been made or modified in this way, this is considered to be a violation of the copyright laws and gives the copyright owner the right to claim for damages. For this reason, avoid the illegal use of material which is protected by copyright.

Windows is a registered trademark of Microsoft Corporation in the United States and/or other countries.

Powered by JBlend™ Copyright 1997-2006 Aplix Corporation. All rights reserved.
JBlend and all JBlend-based trademarks and logos are trademarks or registered trademarks of Aplix Corporation in Japan and other countries.



Powered by Mascot Capsule®/Micro3D Edition™
Mascot Capsule® is a registered trademark of HI Corporation
©2002-2006 HI Corporation. All Rights Reserved.

Licensed by Inter Digital Technology Corporation under one or more of the following United States Patents and/or their domestic or foreign counterparts and other patents pending, including U.S. Patents: 4,675,863; 4,779,262; 4,785,450; 4,811,420; 5,228,056; 5,420,896; 5,799,010; 5,166,951; 5,179,571 & 5,345,467

T9 Text Input is licensed under one or more of the following: U.S. Pat. Nos. 5,818,437, 5,953,541, 5,187,480, 5,945,928, and 6,011,554; Australian Pat. No. 727539; Canadian Pat. No. 1,331,057; United Kingdom Pat. No. 2238414B; Hong Kong Standard Pat. No. HK0940329; Republic of Singapore Pat. No. 51383; Euro. Pat. No. 0 842 463 (96927260.8) DE/DK, FI, FR, IT, NL,PT.ES,SE,GB; Republic of Korea Pat. Nos. KR201211B1 and KR226206B1; and additional patents are pending worldwide.

T9 Text Input is covered by the Hong Kong Standard Patent No. HK0940329 and HK1010924.

T9 Text Input is licensed under one or more of the following: U.S. Pat. Nos. 5,818,437, 5,953,541, 5,187,480, 5,945,928, and 6,011,554; Australian Pat. No. 727539; Canadian Pat. No. 1,331,057; United Kingdom Pat. No. 2238414B; Hong Kong Standard Pat. No. HK0940329; Republic of Singapore Pat. No. 51383; Euro. Pat. No. 0 842 463 (96927260.8) DE/DK, FI, FR, IT, NL,PT.ES,SE,GB; Republic of Korea Pat. Nos. KR201211B1 and KR226206B1; and additional patents are pending worldwide.



microSD™ is a trade mark of SD Card Association.

Bluetooth is a trademark of the Bluetooth SIG, Inc.



The Bluetooth word mark and logos are owned by the Bluetooth SIG, Inc. and any use of such marks by Sharp is under license. Other trademarks and trade names are those of their respective owners.

Contains Macromedia® Flash™ technology by Macromedia, Inc.

Copyright © 1995-2005 Macromedia, Inc. All rights reserved.

Macromedia, Flash, Macromedia Flash, and Macromedia Flash Lite are trademarks or registered trademarks of Macromedia, Inc. in the United States and other countries.



Licensed by QUALCOMM Incorporated under one or more of the following United States Patents and/or their counterparts in other nations ;

4,901,307	5,490,165	5,056,109	5,504,773	5,101,501
5,506,865	5,109,390	5,511,073	5,228,054	5,535,239
5,267,261	5,544,196	5,267,262	5,568,483	5,337,338
5,600,754	5,414,796	5,657,420	5,416,797	5,659,569
5,710,784	5,778,338			



This device includes RSA® BSAFE™ Cryptographic software from RSA Security Inc. RSA is a registered trademark of RSA Security Inc. BSAFE is a registered trademark of RSA Security Inc. in the United States and other countries.

BROWSER BY



OPENWAVE

CP8 PATENT

This product is licensed under the MPEG-4 Visual Patent Portfolio License for the personal and non-commercial use of a consumer to (i) encode video in compliance with the MPEG-4 Video Standard ("MPEG-4 Video") and/or (ii) decode MPEG-4 Video that was encoded by a consumer engaged in a personal and non-commercial activity and/or was obtained from a licensed video provider. No license is granted or implied for any other use. Additional information may be obtained from MPEG LA. See <http://www.mpegla.com>.

This product is licensed under the MPEG-4 Systems Patent Portfolio License for encoding in compliance with the MPEG-4 Systems Standard, except that an additional license and payment of royalties are necessary for encoding in connection with (i) data stored or replicated in physical media which is paid for on a title by title basis and/or (ii) data which is paid for on a title by title basis and is transmitted to an end user for permanent storage and/or use. Such additional license may be obtained from MPEG LA, LLC. See <http://www.mpegla.com> for additional details.

MPEG Layer-3 audio coding technology licensed from Fraunhofer IIS and Thomson.

Useful Functions and Services

Your phone offers you the following features:

- Video Calling. You can talk while viewing each other on respective screens.
- 3D and colour Java™ games and applications with a graphic accelerator. You can also download various games and applications from SmarTone-Vodafone via the mobile Internet.
- Thin Film Transistor (TFT) colour LCD main display with images that are clearer and easier to view.
- A built-in digital camera for taking pictures and video clips.
- A messaging function for reading and creating SMS and MMS messages.
- Email for sending up to 300 KB and receiving mail with attachments.
- A WAP browser for accessing information on the mobile Internet.
- Your own ringtones and ringvideos. You can use downloaded sound or video clip files as a ringtone or ring video clip file.
- Playback of the downloaded sound and video clip files.
- A voice recorder function for recording and playing back voice clips.

- A *Bluetooth*® wireless technology interface for establishing contact and transmitting data with certain devices. You can transmit pictures, sounds, and video clips to OBEX-enabled phones.
- A schedule alarm for creating and sending schedule entries with alarm settings.
- A microSD™ memory card slot that expands connectivity with a PC using the memory card.

Contents

Introduction	1	Using the Menu	30
Getting Started	8	Top Menu	30
Inserting the SIM/USIM Card and the Battery	11	List of Menu Functions	30
Removing the SIM/USIM Card and the Battery ...	12	Entering Characters	32
Charging the Battery	13	Changing the Input Language	33
Inserting/Removing the Memory Card	14	Changing the Input Method	33
Connecting the Handsfree Kit	16	Chinese User Dictionary	38
Turning Your Phone On and Off	17	Using Templates	41
Keypad Lock	17	Copying, Cutting and Pasting Text	41
Display Indicators (Main Display)	18	Insert Phonebook Entries	41
Display Indicators (External Display)	20	Call Manager	42
Navigating Functions	21	Changing the List Displayed	43
Voice Call/Video Calling Functions	22	Selecting the Storage Memory	43
Making a Voice Call	22	Sorting the Phonebook List Order	43
Speed Dialling	23	Selecting the Search Mode	43
Redialling	23	Add New	43
Answering a Voice Call	23	Viewing My Card	44
Incall Menu (Voice Call)	24	Copying Phonebook Entries between	
Making a Video Calling	27	SIM/USIM Card and Handset	44
Answering a Video Calling	27	Dialling from the Phonebook	44
Incall Menu (Video Calling)	28	Editing Phonebook Entries	45

Assigning a Ringtone or a Ring Video Clip File to Each Entry	45	Cell Broadcasts	61
Deleting Phonebook Entries	45	Area Info	62
Manage Group	46	Messaging Settings	62
Message Groups	46	Browser	65
Memory Status	47	Navigating a WAP Page	66
Speed Dial List	47	Media Player	69
Sending a Phonebook Entry	48	TV & Video	69
Receiving a Phonebook Entry	48	Music Player	71
Sending a Voice Clip Message or Video Clip Message Using an Address from the Phonebook	48	Gallery	74
Camera	49	Picture Gallery	74
Taking Pictures	49	Video Gallery	75
Recording Video Clips	50	Sound Gallery	76
Common Functions in the Photo and Video Camera Modes	50	Other Documents	77
Functions in the Photo Camera Mode	52	Common Option Menus	77
Functions in the Video Camera Mode	54	Text Templates	80
Messages	56	Memory Status	80
SMS	56	Games & Applications	81
MMS	56	GSX™ & Java™ Gallery	81
Email	56	Set Java™ Wallpaper	83
Creating a New Message	56	Java™ Settings	84
		Java™ Information	85
		Organiser	86
		Calendar	86
		Alarms	89

Calculator	90	Connectivity	115
Voice Recorder	91	Bluetooth	115
Stopwatch	92	Network Settings	118
Tasks	92	Internet Settings	119
World Clock	94	Off Line Mode	120
Countdown Timer	94	Backup/Restore	121
Expenses Memo	95	Connecting SX633A to Your PC	122
Phone Help	95	System Requirements	122
SIM Application	96	3G/GSM GPRS Modem	122
Settings	97	Handset Manager	123
Profiles	97	Software Installation	123
Setting the Display	101	Troubleshooting	124
Sound Settings	104	Safety Precautions and Conditions of Use	126
Date & Time	104	Conditions of Use	126
Language Setting	105	Environment	128
Call Settings	106	Precautions Concerning Vehicle Use	128
Video Calling Settings	110	SAR	129
Security	111	FCC NOTICE	129
Card Settings	113	Out of Warranty List	131
Master Reset	113	Index	132
Call Log	114		
Call Timers	114		
Data Counter	114		

Getting Started

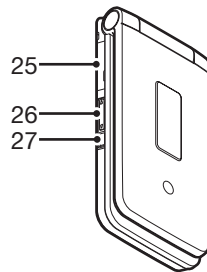
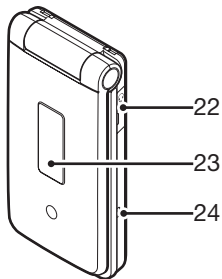
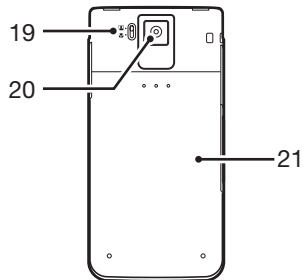
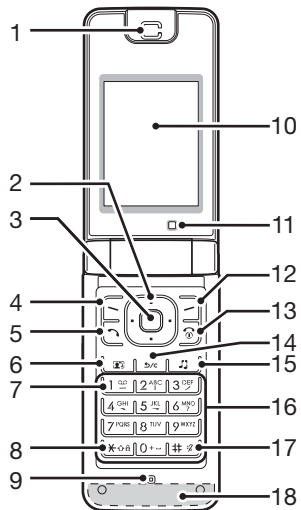

1. Earpiece

2. Navigation Keys (Arrow Keys):

Up arrow key:



Moves cursor to highlight a menu item, etc.

Displays the Shortcut menu when pressed in standby.

indicates this key in this manual.

Down arrow key:



Displays the Phonebook entries when pressed in standby.

indicates this key in this manual.

Left arrow key:



Displays the list of GSX™ & Java™ Gallery when pressed in standby.

indicates this key in this manual.

Right arrow key:



Displays Gallery when pressed in standby.

indicates this key in this manual.

3. Centre Key:



Displays the Main menu in standby, and executes the highlighted function.

4. Left Soft Key:



Executes the function in the lower left of the screen.

Displays Messaging menu in standby.

5. Send/Redial Key:



Makes or accepts calls, displays the call logs in standby.

6. Video Calling Key:



Makes or accepts Video Callings.

7. Voice Mail Key:



Long press to connect to the Voice mail centre. (Depending on the SIM/USIM card.)

8. * /Shift Key:



Switches character input method as follows on the text entry screen.

In English mode: Abc, ABC, abc and 123. In T9 mode, T9 Abc, T9 ABC, T9 abc and 123.

In Traditional Chinese mode: Abc, ABC, abc, 123, and T9 Stroke

In Simplified Chinese mode: Abc, ABC, abc, 123, T9 PinYin, and T9 Stroke

Press to enter P, ?, – or * in standby.

Long press in standby to lock the keypad.

9. Microphone

10. Main Display

11. Sub Camera (Internal Camera)

12. Right Soft Key:



Executes the function in the lower right of the screen. Shortcut to “SmarTone *iM!*” by opening the browser. Press in standby.

13. End/Power Key:



Ends a call and turns power on/off.

14. Clear/Back Key:



Clears the characters before the cursor, returns to the previous screen, etc.

15. Music Key:



Displays Music menu in standby.

16. Keypad

17. #/Silent Key:



Displays symbol screen on the text entry screen.

Long press to switch languages on the text entry screen.

Long press in standby to switch Profiles settings between the mode most recently activated and Silent mode.

18. Built-in Aerial:

Warning: Do not cover the lower part of the phone with your hand when in use as this may interfere with the performance of the built-in aerial.

19. Portrait ()/Macro () Selector

20. Camera (External Camera)

21. Battery Cover

22. Handsfree Kit Connector

23. External Display

24. Small Light:

Used as a battery charge indicator, Event Light and Status Light.

25. External Connector:

Used to connect either the charger or a USB data cable.

26. Side Keys ( / ):

Moves the highlight up or down.

Press in standby or during a call to increase or decrease the earpiece volume.

27. Voice Recorder Key:

Activates the Voice Recorder.

Inserting the SIM/USIM Card and the Battery

1. Slide off the battery cover (① ②).

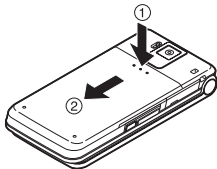

2. Slide the SIM/USIM card into the SIM/USIM holder.

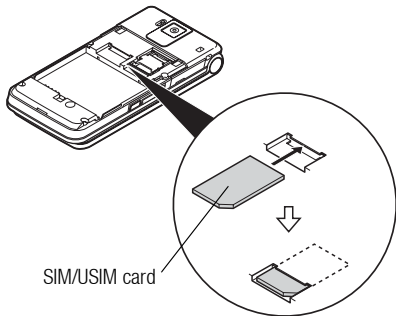

3. Hold the battery so that the metal contacts of the battery are facing down, slide the guides on the top of the battery into the battery slots ③, and then insert it ④.

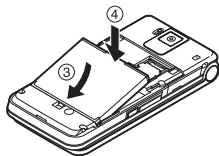

4. Replace the battery cover.

Note

- Make sure that only 3V SIM/USIM cards are used.
- Make sure that the standard accessory battery is used.

Removing the SIM/USIM Card and the Battery

1. Ensure that the phone is turned off and that the charger and other accessories are disconnected. Slide off the battery cover.
2. Lift the battery using the protruding edge and remove the battery from the phone.
3. Slide the SIM/USIM card out of the SIM/USIM holder.

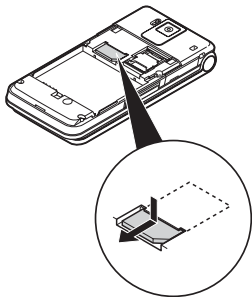

4. Hold the battery so that the metal contacts are facing down and slide them into the slots. Close the cover.

Battery Disposal

The device is battery-powered. In order to protect the environment, please read the following points concerning battery disposal:

- Take the used battery to your local waste depot, dealer or customer service centre for recycling.
- Do not expose the used battery to a naked flame, immerse in water or dispose with the household waste.

Charging the Battery

Using the Charger

1. Open and rotate the cover of the external connector halfway around, connect the charger to the external socket located on the side of the phone by pressing both sides indicated with arrows, and connect to an AC outlet.

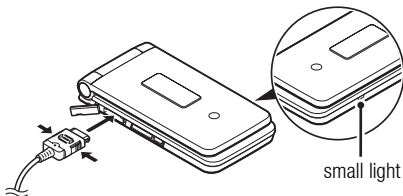

The small light turns red.

Standard charging time: Approx. 140 minutes

Note

- When you purchase this phone, the battery may not be fully charged.
- Charging time may vary depending on the state of the battery and other conditions. (See “Battery” on page 126.)

To Disconnect the Charger

When charging is complete, the small light turns off.

1. Unplug the charger from the AC outlet, then unplug the charger connector from the phone by pressing both sides indicated with arrows in the figure.
2. Close the cover.

Note

- Do not use any non–approved chargers as they may damage your phone and invalidate any warranties, see “Battery” on page 126 for details.

To Charge Using the Cigarette Lighter Charger

The optional cigarette lighter charger supplies power for charging from the cigarette lighter socket of a car.





Battery Level Indicator

The current battery level is displayed in the upper right of the main display.

Low Battery during Use

When the battery is running low, an alarm will sound and “” is displayed on the main and external displays.

If you are using your phone and you hear the low battery alarm, attach your charger as soon as possible. The phone may not be able to continue normal operation if you continue to use it.

Battery Indicators	Charge Level
	Sufficiently charged
	Charging recommended
	Charging required
	Empty

Inserting/Removing the Memory Card

Note

- Do not push or pull on the card holder excessively as it could break. The holder is thin and particularly fragile.
- Do not touch the metal terminals with your hands or metal objects.
- Make sure that the phone is turned off before inserting/removing the memory card.
- Be sure to insert the card in the correct direction and orientation.
- Keep all memory cards out of the reach of small children.

To Insert the Memory Card

1. Turn off the phone.
2. Slide off the battery cover.



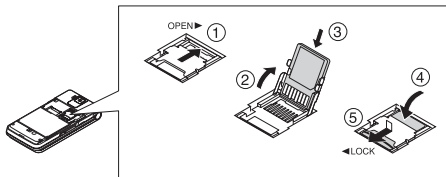

3. Slide the card holder as shown below in ① (OPEN ►) and insert the memory card as shown in ② to ⑤.



4. Close the cover.

Tip

- You see the following indicators when the memory card is in use:

-  : Appears when the card is inserted.
-  : Appears when the card is damaged or unusable.
Make sure the card is properly inserted.
-  : Appears when the card is being written to or read.
-  : Appears when the card is being formatted.

To Remove the Memory Card

1. Turn off the phone.
2. Slide off the battery cover.
3. While pressing down lightly on the cover, slide the card holder as shown below in ① (OPEN ►) and remove the memory card as shown in ② to ⑤.

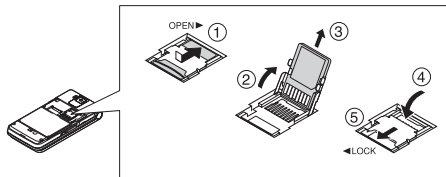

4. Close the cover.

Connecting the Handsfree Kit

1. Open and rotate the connector cover halfway around.
2. Connect the handsfree kit.

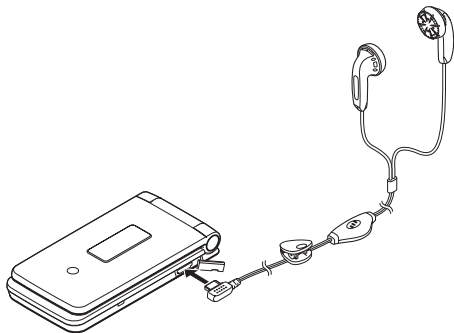

Turning Your Phone On and Off

To turn the power on, long press  for approximately 2 seconds.

To Enter the PIN Code

If activated you are asked to enter a PIN (Personal Identification Number) code and handset lock code after turning on your phone.

1. Enter your PIN code.

The PIN code is 4 to 8 digits.

2. Press .

Note

- If your PIN code is entered incorrectly three times in a row, the SIM/USIM card is locked. See “Enabling/Disabling the PIN Code” on page 111.
- If the clock settings have not been entered, the date and time entry screen is displayed (p. 104).

To Copy All Phonebook Entries from the SIM/USIM Card

When you insert the SIM/USIM card into your phone for the first time and start the Phonebook application, you are asked whether you wish to copy Phonebook entries on the SIM/USIM card. Follow the on-screen instructions, or you can do it later using the Phonebook menu as follows:

“Call Manager” → “Advanced” → “Copy All Entries”

1. Select “From SIM to Handset”.

Keypad Lock

You can lock the keypad to prevent it from being pressed accidentally.

Locking the Keypad

1. Long press  in standby.









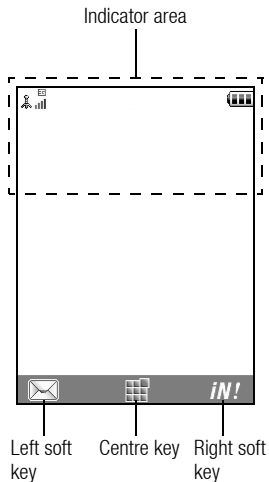











To unlock, long press .

































Tip

- Emergency numbers (999, etc.) can be entered and dialled regardless of the keypad lock.

Display Indicators (Main Display)











-   : Strength of received signal/Service out of range
 : 3G (UMTS)/GPRS
 : GSM/GPRS
 : Roaming outside network
-  : Off Line Mode [enabled]
-  : Data exchange with external device
-   : Connection to the server [established/communicating]
-  : Memory card inserted
-   : Voice call [incoming/in progress]
-    : Video calling communication mode enabled [voice and video/voice/video]
-  : Diverts set to "Voice Calls"
-  : Secure WAP page displayed
-    : Alerts [text message/multimedia message/email]

11.  /  /  / : Connection status
[USB working/*Bluetooth* standby/*Bluetooth* working/Talking with the *Bluetooth* headset]
12.  / : Java™ application [executed (colour)/suspended (grey)]
13. (No display) /  /  /  /  /  / : Current profile [Normal/Meeting/Activity/Car/Headset/Silent]
14.  /  /  /  / : Silent/vibration setting [silent/increasing volume/vibration enabled/silent and vibration enabled/increasing volume and vibration enabled]
15.  /  / : Speaker mode [speaker phone/speaker activated/microphone muted]
16. : Battery level
17. : Daily alarm enabled
18.  / : Schedule entry enabled [with/without reminder alarm]
19. : Outbox contains unsent messages [text message/multimedia/email]
20.  /  / : WAP/OTA provisioning alerts [WAP alert/OTA provisioning alert/WAP and OTA provisioning alerts]
21. : Voice mail message alert
22. : Function Lock enabled
23. : Keypad Lock enabled
24.  / : Phonebook Search Mode

Display Indicators (External Display)



Status Indicators

1. : Battery level
2. : Strength of received signal/Service out of range
3. : Missed events
4. : Voice call incoming
5. : Video calling incoming
6. : Call in progress
7. : Alerts [messages/Delivery Report]
8. : WAP Push service
9. : Daily alarm enabled

Note

- *The above indicators may appear/disappear depending on the situation.*

Navigating Functions

All applications are accessed from the Main menu. To open the Main menu, press the centre key (○) in standby.

To launch applications, you will need to highlight menu items, and make selections. To select a menu item (indicated in quotation marks), move the cursor using ▲, ▼, ◀ and ▶, and press ○ to select.

In certain procedures, you will need to press one of the soft keys (indicated in square brackets), which are displayed in the lower left and right of the screen. Press the corresponding soft key (☐ or ☐).

To return to the previous screen, press the right soft key if it displays *Back*. To close the Main menu, press the right soft key if it displays *Exit*.

Each section in this user guide starts with a list of items you will need to select in order (indicated in italics) before performing the procedures shown. Select each item to reveal the next set of items that you have to select. Open subsection items after opening those listed in the main section.

Example:

“Call Manager” → ***“Phonebook”*** → ***“Add New”***

Voice Call/Video Calling Functions

Making a Voice Call

1. Enter the area code and the phone number you wish to dial and press  to dial.

If you enter the wrong number, press  to delete the number to the left of the cursor.



Emergency Calls

1. Enter 999 or 911 (international emergency number) using the keypad and press  to dial.

Note

- *Emergency calls may not be able to be made on all mobile phone networks when certain network services and/or phone features are in use. Contact your network operator for more information.*
- *This emergency number can normally be used to make an emergency call in any country, with or without a SIM/USIM card inserted, if a 3G (UMTS)/GSM network is within range.*

International Calls

1. Long press  until a + (international dialling prefix) sign is displayed.
2. Enter the country code, followed by the area code (without the leading zero) and the phone number, and press  to dial.

Adding an Entered Phone Number to the Phonebook

1. After entering a phone number, press [Options] and select “Save Number”.

For details on creating a new entry, see “Add New” on page 43.

Showing or Hiding My Phone Number on the Display of the Called Party

1. After entering a phone number, press [Options] and select “Hide My ID” or “Show My ID”.

Speed Dialling

Up to 8 phone numbers from the Phonebook memory (Handset and SIM/USIM) can be assigned to speed dials. You can call the numbers using the digit keys (1 to 9). The phone number of the Voice mail centre is assigned to 1.

For details on setting the speed dial list, see “Speed Dial List” on page 47.



1. To dial a number using the speed dial, long press any of the digit keys (1 to 9).

The phone number saved in the speed dial list is dialled.

Redialling

You can redial numbers in the call log. Select from specific categories or “All Calls”. Specific categories contain up to 30 numbers and the “All Calls” list contains up to 90.



1. Press  in standby.
2. Select the category from “All Calls”, “Dialled Numbers”, “Missed Calls” or “Received Calls”.

To switch logs, press  or .

3. Highlight the phone number you wish to call.
4. Press  to redial the call.

Answering a Voice Call

When an incoming call is detected, the phone rings.

1. Press ,  or press [Options] and select “Answer” to answer the call.

Or press any key (except ,  and [Busy]) when the “Any Key Answer” function is enabled. Set the Any Key Answer function in the profile of each mode (p. 100).

Tip

- If you have subscribed to the Calling Line Identification (CLI) service and the caller's network sends the number, the caller's number is displayed on the screen. If the caller's name and number are saved in the Phonebook, the caller's name is displayed on the screen.
- If the number is a restricted number, the display shows “Withheld”.
- When you receive a call from the person whose picture is registered in the Phonebook, the picture, name and phone number are displayed.

Rejecting an Incoming Call

1. Press [Options] and select “Reject Call” while the phone is ringing to reject a call you do not wish to answer.

Forwarding an Incoming Call to the Voice Mail Centre









1. Press [Busy] or  while the phone is ringing to forward the call to the Voice Mail centre.

Incall Menu (Voice Call)

Your phone has additional functions available while a call is in progress.

Adjusting the Earpiece Volume

During a call, you can adjust the earpiece volume (and handsfree kit volume, if connected).

1. Press  or  to display the Earpiece Volume screen.
2. Press  (or /) to increase the volume of the call or press  (or /) to decrease the volume.
3. Press  when the volume is set to the desired level.

Turning the Speaker On and Off

You can talk via the loudspeaker on the back of the phone by turning it on.

1. During a call, press [Options] and select “Loudspeaker On”.

Putting a Call on Hold

This function allows you to manage two calls at the same time. If you wish to make another call while you are talking to someone, you can put the current call on hold to call someone else.

To Make Another Call during a Call

1. During a call, press [Options] and select “Hold”.
The current call is put on hold.
2. Press [Options] and select “Dial New Number”.
3. Enter the phone number you wish to make another call to, then press .

Tip

- You can also make another call by entering the phone number during a call instead of step 1. The current call is automatically put on hold.

Accessing SMS/MMS Menu during a Call

1. During a call, press [Options] and select “Messages”.

The following options are available: “Create Message” to make an SMS and MMS, or “Inbox”, “Sent” or “Drafts” to access these folders. For details on SMS, see “SMS” and “MMS” on page 56.

Call Waiting

This service notifies you of another incoming call while you have a call in progress.

1. During a call, press [Options] and select “Hold & Answer” to answer the second call.

The first call is put on hold and you can now talk to the second caller.

Note

- You need to set “Call Waiting” to “On” if you use the Call Waiting service (p. 107).
- Call Waiting service may not be available on all networks. Contact your network operator for more information.
- If you do not wish to answer the second call, press [Options] and select “Busy” in step 1. If “Reject” is selected, the log of the second call is saved as a missed call.

Conference Call

Conference call is a call with more than 2 participants. You may include up to 5 participants in a conference call.

To Make a Conference Call

You must have one active call and one held call.

1. During a call, press [Options] and select “Multi Party”.
2. Select “Conference All” to join the conference call.
3. Press  to end the conference call.

Note

- The conference call service may not be available on all networks. Contact your network operator for more information.
- You have more options for the Conference call in step 2:
 - To put all participants on hold, select “Hold All”.
 - To put all participants except the current call on hold, select “Private”.
 - To end the call with all participants, select “End Active Call(s)” or “End Held Call(s)”.
 - To reject adding more participants to the current party, press [Options] and select “Reject”, or you can forward the call to the Voice Mail centre by selecting “Busy” or .

To Add New Participants to the Conference Call

1. Press [Options] and select “Dial New Number”.
2. Enter the number you wish to include in the conference call and press  to dial.
3. Press [Options] and select “Multi Party”.
4. Select “Conference All” to join the conference call.
If you wish to add other participants, repeat steps 1 to 4.

To End the Call with a Conference Call Participant

1. During a conference call, highlight the person that you wish to disconnect from the conference call.
2. Press [Options] and select “End Active Call(s)” or “End Held Call(s)”.

To Have a Private Conversation with One of the Participants

If you wish to have a private conversation with one of the participants, you may select the participant from the conference list and put the other participants on hold.

1. During a conference call, select the person that you wish to talk to.
2. Press [Options] and select “Multi Party”.
3. Select “Private”.
4. Once you have finished the private conversation, press [Options] and select “Multi Party”.
5. Select “Conference All” to return to the conference call.

Muting the Microphone

1. During a call, press [Mute].
To unmute the microphone, press [Unmute].

Making a Video Calling

Note

- Use this function with only the video calling enabled phones.
- Make sure that the battery is fully charged and the signal is strong before using this function.
- Turn the loudspeaker on or use a handsfree kit so that you can talk while looking at the video calling screen on the main display.

Making a Video Calling

1. Enter the area code and the phone number you wish to dial and press , or press [Options] and select “Video Calling” to dial.

If you enter the wrong number, press  to delete the number to the left of the cursor.



When the line is connected, the image of the called party is displayed upper on the screen, and yours lower left.

Tip

- If the called party's phone is not video calling enabled, you can press  and enter the phone number again to make a voice call.

Answering a Video Calling

When an incoming call is detected, the phone rings.

1. Press  or  to answer the call by video or press [Options] and select “Hide Picture” to answer with voice only.

Tip

- If you have subscribed to the Calling Line Identification (CLI) service and the caller's network sends the number, the caller's number is displayed on the screen. If the caller's name and number are saved in the Phonebook, the caller's name and phone number are displayed on the screen.

Rejecting an Incoming Call

1. Press [Options] and select “Reject Call” while the phone is ringing to reject a call you do not wish to answer.

Forwarding an Incoming Call to the Voice Mail Centre

1. Press [Busy] or  while the phone is ringing to forward the call to the Voice Mail centre.

Incall Menu (Video Calling)

Muting the Microphone

1. During a video calling, press [Mute].
To unmute the microphone, press [Unmute].

Switching Images

You can switch images between the main and sub screens.

1. During a video calling, press [Options] and select “Switch Images”.

Tip

- You can also switch images between the main and sub screens by pressing  during a video calling.

Changing the Image of Yourself



1. During a video calling, press [Options] and select “Camera Picture”.
2. Select “Internal Camera”, “External Camera” or “Alternative Image”.

“Internal Camera”:
The image through the internal camera is displayed and sent to the party.

“External Camera”:
The image through the external camera is displayed and sent to the party.

“Alternative Image”:
The camera is turned off and the image selected in “Alternative Image” of “Video Calling Settings” (p. 110) is used.

Tip

- You can also switch the image shown to the caller by pressing  or  during a video calling.

Turning the Speaker On and Off

You can talk via the loudspeaker on the back of the phone by turning it on.

1. During a video calling, press [Options] and select “Loudspeaker On”.

Note

- In a high-noise environment, you may not be able to continue a call, or make a clear call. We recommend that you use the handsfree kit.
- With this option, you may not be able to continue a call without interruption if you increase the earpiece volume. We recommend that you decrease the earpiece volume or use the handsfree kit.

Video Calling Settings

To Change the Quality of the Incoming Image

You can adjust the quality of the called party's image.

1. During a video calling, press [Options] and select "Video Calling Settings".
2. Select "Incoming Picture Quality".
3. Select "Normal", "Quality Priority" or "Frame Rate Priority".

"Normal":	The standard quality is used.
"Quality Priority":	The quality of the picture takes precedence over the frame rate.
"Frame Rate Priority":	The frame rate takes precedence over the quality.

To Turn the Backlight On or Off



You can turn on the backlight of your screen.

1. During a video calling, press [Options] and select "Video Calling Settings".
2. Select "Backlight".
3. Select "Always On", "Always Off" or "As Normal Setting".

When "Always On" is selected, the backlight will always be on during a video calling.

When "As Normal Setting" is selected, the backlight will time out depending on the Backlight setting (p. 102).

To Adjust the Video Exposure

1. During a video calling, press [Options] and select "Video Calling Settings".
2. Select "Exposure".
3. Press  (Bright) or  (Dark).

Mirror Image

During a video calling, you can reverse your image on the sub screen.

1. During a video calling, press [Options] and select "Video Calling Settings".
2. Select "Mirror Image".
3. Select "On" or "Off".

To Change the Sub Camera Image to the Alternative Image

During a video calling, you can switch the image shown to the caller between the sub camera image and an alternative image or display an image while putting a call on hold from the saved picture files.

1. During a video calling, press [Options] and select "Video Calling Settings".
2. Select "Alternative Image" or "Hold Guidance Picture".
3. Select "Preset Picture" or "Picture Gallery".

Using the Menu

Top Menu

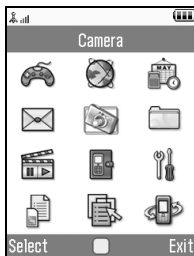

1. Press **○** in standby.
The Main menu is displayed.
2. Press **▲**, **▼**, **⊙** or **▶** to highlight the desired menu, then press **○** to access the function.
The sub menu is displayed.
For details on the menu options, see "List of Menu Functions".

List of Menu Functions

Menu No./Main Menu	Menu No./Sub Menu1
1 Games & Applications	1 GSX™ & Java™ Gallery
	2 Set Java™ Wallpaper
	3 Java™ Settings
	4 Java™ Information
2 Browser	1 Homepage
	2 Go to URL
	3 Bookmarks
	4 Alert Inbox
	5 My Saved Page
	6 Access History
	7 Browser Settings
	8 PLUS
	9 News
	10 Music
	11 Games
	12 Sports
	13 What's New?
	14 Email
3 Organiser	1 Calendar
	2 Alarms
	3 Calculator
	4 Voice Recorder
	5 Stopwatch
	6 Tasks
	7 World Clock
	8 Countdown Timer
	9 Expenses Memo
	10 Phone Help

Menu No./Main Menu	Menu No./Sub Menu1
4 Messages	1 Create Message
	2 Inbox
	3 Alert Inbox
	4 Drafts
	5 Templates
	6 Sent
	7 Outbox
	8 Voice Mail
	9 Cell Broadcasts
	10 Area Info
	11 Messaging Settings
	12 Memory Status
5 Camera	
6 Gallery	1 Picture Gallery
	2 Video Gallery
	3 SD VIDEO
	4 Sound Gallery
	5 GSX™ & Java™ Gallery
	6 Text Templates
	7 Other Documents
	8 Memory Status
7 Media Player	1 TV & Video
	2 Music Player
8 Call Manager	1 Phonebook
	2 Manage Group
	3 Speed Dial List
	4 My Card
	5 Message Groups
	6 Phonebook Settings
	7 Advanced

Menu No./Main Menu	Menu No./Sub Menu1
9 Settings	1 Profiles
	2 Display Settings
	3 Sound Settings
	4 Date & Time
	5 Language
	6 Call Settings
	7 Video Calling Settings
	8 Security Settings
	9 Card Settings
	10 Master Reset
10 SIM Application	
11 Call Log	1 All Calls
	2 Dialed Numbers
	3 Missed Calls
	4 Received Calls
	5 Call Timers
	6 Data Counter
12 Connectivity	1 Bluetooth
	2 Network Settings
	3 Internet Settings
	4 Off Line Mode
	5 Backup/Restore

Entering Characters









When entering characters to create Phonebook entries, SMS or MMS, etc., press the corresponding keys.





In multi-tap input method, press each key until the desired character is displayed. For example, press  once for the letter "A" or twice for the letter "B".

Multi-tap Mode

Pressing each key scrolls characters in the following order.

Multi-tap Mode keys

Key	Upper Case Characters	Lower Case Characters	Numeric
	. (full-stop) , (comma) ? ! : ; ' (apostrophe) " / 1		1
	ABC2	abc2	2
	DEF3	def3	3
	GHI4	ghi4	4
	JKL5	jkl5	5
	MNO6	mno6	6
	PQRS7	pqrs7	7
	TUV8	tuv8	8

Key	Upper Case Characters	Lower Case Characters	Numeric
	WXYZ9	wxyz9	9
	(space)+ = < > € £ \$ ¥ % & 0		0
	Switches character case among four modes: Abc, ABC, 123 and abc.		
	. , ? ! : ; ' " [SP] _ @ / \ # * = ^ ` i - (< [\$ £ ¥ € § ß -) >] Ä Å Æ Ü ü ù + { å ä æ à ç È é è é & } i ñ Ñ Ö Ø ö ø ò ~ Δ Φ Γ Λ Ω Π Ψ Σ Θ % Ξ □		

 -  : Long press to enter 1 - 9 numbers.

 : Long press to enter space in Numeric mode or to enter 0 in other modes.

 : Long press to shift between multi-tap and T9 mode.

 : Long press to display the Input Language screen.

Changing the Input Language

1. On the text entry screen, press [Options].
2. Select “Input Language”.
3. Select the desired language.

Changing the Input Method

1. On the text entry screen, press [Options].
2. Select “Input Method”.
3. Select the input method you wish to use.

Input Method	Input Language = English	Input Language = Traditional Chinese	Input Language = Simplified Chinese
T9 Mode	T9 Abc T9 ABC T9 abc	T9 Stroke	T9 Stroke T9 PinYin
Multi-tap mode	Abc ABC abc Numeric	Abc ABC abc Numeric	Abc ABC abc Numeric
Others	Symbol Table	Symbol Table	Symbol Table

Tip

In T9 or multi-tap mode, you can switch input mode as follows by pressing ***o#**.

English/T9 mode

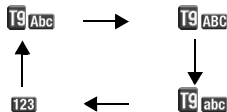

English/Multi-tap mode

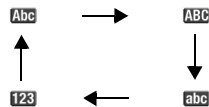

Traditional Chinese/T9 mode



Simplified Chinese/T9 mode



T9 English Mode

Using T9 English Mode

T9 text input method is a shortcut to enter text easily and quickly.

1. On the text entry screen, press [Options].
2. Select “Input Method”.
3. Select the T9 mode (T9 Abc, T9 ABC, T9 abc) you wish to change. “T9” is displayed on the main display.
4. Press the keys to enter characters.
5. Press or to select the word you wish to input.
6. If you wish to clear the word, highlight it and long press .
7. Press or select [Options] and “Done” to complete the selection.

Tip

- If you press instead of step 6, a space is inserted next to the selected word.

User Dictionary

You can create your own English words for T9 Alphabet text input.

Note

- This function is only available when “Input Language” is set to “English”.

1. On the text entry screen in T9 mode, press [Options] and select “User Dictionary”.
2. Select “Add New Word” and enter a new word.

To edit a word in the list

1. On the text entry screen in T9 mode, press [Options] and select “User Dictionary”.
2. Highlight the desired word.
3. Press [Options] and select “Edit”.
4. Modify the word.

Using Stroke Mode (Traditional)

The following is an example of entering “節”.

1. Change the input mode to T9 Stroke mode.
2. Press **3 DEF** **1 QW** **4 GHI** to display the corresponding stroke for “節”.
3. Long press the corresponding key to complete the selection (in this case, **7 PQRS**).



Note

- Each Traditional/Simplified Chinese mode has own T9 Stroke mode. The screen examples in steps 1 to 3 are displayed when you select “Traditional Chinese” in the Input Language option.

Using PinYin Mode

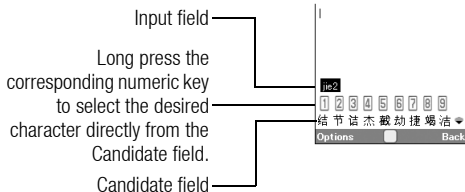

The following is an example of entering “理”.

1. Press **5 AC** for the first letter of the reading, then highlight “l”.

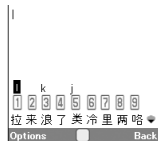

- Press **[4^{CH}]** for the vowel of the first letter, then highlight “ji”. Characters with the same reading are displayed in the Candidate field.

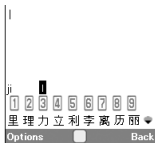

- Select the desired character.
- Long press corresponding numeric key to enter the desired character (in this case, **[2^{ABC}]**).

Tip

- When the cursor is placed after the first character, the Candidate field displays characters most likely to follow.

- If you want to use tone options, long press **[*0.6]** instead of step 3 to display the desired character. The tone symbols are displayed in the Candidate field. Press the corresponding numeric key (**[2^{ABC}]**).

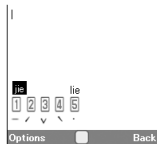

Chinese User Dictionary

You can create your own word list for T9 Chinese input.

You can enter Chinese characters, alphabet, symbols and numbers. Only capital letters can be used for acronyms.

Note

- *This function is only available when “Input Language” is set to “Traditional Chinese” or “Simplified Chinese”.*

Creating a New Entry

1. On the text entry screen, press [Options] and select “Chinese User Dictionary”.
2. Select “Add New Word”.
3. Enter new word.
4. Enter acronym.

Editing a Word in the List

1. On the text entry screen, press [Options] and select “Chinese User Dictionary”.
2. Highlight the desired word.
3. Press [Options] and select “Edit”.
4. Modify the entry word.
5. Modify the acronym.

Deleting a Word

1. On the text entry screen, press [Options] and select “Chinese User Dictionary”.
2. Highlight the desired word.
3. Press [Options] and select “Delete”.
4. Press [Yes] or [No].

To Call the Entry

Examples of entry words and acronyms:

Entry Word	Acronym
四	→ S
四百	→ SB
四川	→ SC
四川牛肉面	→ SCNRM

↕ New
↕ Old

The illustration below assumes that the example entry words and acronyms are already stored.

1. Press $\overline{7^{T9}}$ and highlight “S”.

If you long press $\overline{1^{SC}}$, “四” will be entered.

You can also select the other words starting with the same acronym by pressing $\overline{1^{SC}}$.

2. Press $\overline{2^{SB}}$ and highlight “SB”.

If you long press $\overline{1^{SC}}$, “四百” will be entered.

This example is using T9 PinYin mode



Press $\overline{1^{SC}}$

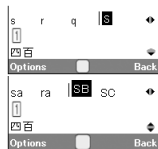

Note

- Acronyms are available for T9 PinYin mode only.
- You can also enjoy word completion or predictive input of the words stored in the Chinese User Dictionary. When the first three characters of a word are entered, the whole word appears at once.

The following is an example of predictive input and word completion. This example uses words stored in the last section.

1. Press $\overline{2^{SC}}$, $\overline{5^{SL}}$, $\overline{3^{SZ}}$ and long press $\overline{2^{SC}}$ to enter “四”.

2. The character “川” appears at $\overline{8}$.

(Candidates $\overline{8}$ and $\overline{9}$ are taken from the Chinese User Dictionary.)

This example is using Stroke input method for Simplified







3. Long press  to enter “川”.



4. Long press  to enter “牛”.

The sentence is completed automatically.

Note

- Word completion does not take place if the entry word has less than four Chinese characters.
- Predictive characters from the Chinese User Dictionary appear at , so you only have to press  to enter the characters.
If there are entry words which start with the same characters such as “四時半” and “四川”, candidates “时” and “川” appear at  or , depending on the sequence in which the words are saved.





Symbols and Punctuations

1. On the text entry screen, press [Options].

2. Select “Add Symbol”.

The first symbol page is displayed.

In Chinese input mode, the FullWidth Symbols screen is displayed.

3. Press  or  to switch pages (HalfWidth Symbol and FullWidth Symbol Pages), or use the numeric keys  or .

Tip

-  is a shortcut to launch Symbol Tables.

Using Templates

You can use the sentences registered in Text Templates when entering characters.

For details on creating the text template, see “Adding Phrases to Text Templates” on page 80.

1. On the text entry screen, move the cursor to the point you wish to insert the template.
2. Press [Options] and select “Advanced”.
3. Select “Insert Template”.
4. Select the desired text template.

The selected text template is inserted.

Copying, Cutting and Pasting Text

1. On the text entry screen, press [Options] and select “Advanced”.
2. Select “Copy” or “Cut”.
3. Move the cursor to the first letter to be copied or to be cut, then press .
4. Move the cursor to the last letter to highlight the area, then press .
5. Move the cursor to the point you wish to paste the letters.
6. Press [Options] and select “Advanced”.
7. Select “Paste”.

Insert Phonebook Entries

You can insert the entries registered in Phonebook when entering characters.

For details on creating the Phonebook entries, see “Call Manager” on page 42.

1. On the text entry screen, move the cursor to the point you wish to insert the Phonebook Entry.
2. Press [Options] and select “Advanced”.
3. Select “Insert Phonebook Entry”.
4. Select the desired Phonebook Entry.

The selected entry is inserted.

Call Manager (M 8)

You can store the phone numbers and Email addresses of your friends, family and colleagues in the Phonebook.

Your phone can store up to 500 entries. In a Phonebook, you can save the following items:

Items Saved in the Handset Memory

Last Name	up to 16 characters
First Name	up to 16 characters
Add Phone Number	up to 3 phone numbers (up to 32 digits each)
Add Email Address	up to 3 Email addresses (up to 128 characters each)
Group	16 groups
Street Name	up to 64 characters
City Name	up to 64 characters
State Name	up to 64 characters
Postal Code	up to 20 characters
Country Name	up to 32 characters
Note	up to 256 characters
Birthday	(date)

Picture	(file name)
Assign Tone/Video	(file name)
Secret	(On or Off)

Items Saved in the SIM/USIM Memory

Name	up to 16 characters
Add Phone Number	1 phone number (up to 32 digits)
Add Email Address	1 Email address (up to 38 characters)
Group	up to 16 groups

Note

- *Each item depends on SIM/USIM Cards.*

Changing the List Displayed

“Call Manager” → ***“Phonebook Settings”*** → ***“Source”***

1. Select “Handset” or “SIM”.

Selecting the Storage Memory

“Call Manager” → ***“Phonebook Settings”*** → ***“Save to”***

1. Select “Handset”, “SIM” or “Choice”.

Sorting the Phonebook List Order

You can change the listing order of the Phonebook entries between by pinyin order or by group.

“Call Manager” → ***“Phonebook Settings”*** → ***“View Phonebook”***

1. Select “By PinYin” or “By Group”.

Selecting the Search Mode

“Call Manager” → ***“Phonebook Settings”*** → ***“Search Mode”***

1. Select “Character Search”, “PinYin Search” or “English Search”.

Add New

You can choose either the phone or SIM/USIM card memory locations to store the new entry. For switching locations, see “Selecting the Storage Memory”.

The amount of phone numbers that you can store to the SIM/USIM card is dependent on its capacity. Contact your network operator for details.

“Call Manager” → ***“Phonebook”*** → ***“Add New”***

If you select the “Choice” option for the memory to be used, the selection is between “To Handset” and “To SIM”.

1. Select the field you wish to fill in, and enter the relevant information.
2. Press [Save] when finished.

Tip

- To create an entry, at least one field must be filled (“Last Name”, “First Name”, “Add Phone Number” or “Add Email Address” for the handset memory; “Name”, “Add Phone Number” or “Add Email Address” for the SIM/USIM memory).

Adding a Thumbnail to Entries

“Call Manager” → “Phonebook”

1. Highlight the desired entry.
2. Press [Options] and select “Edit”.
3. Select “Picture”.
4. Select “Assign Picture”.
5. Select the desired picture.
6. Press [Save] when finished.

Note

- If you delete a picture in the handset memory, the corresponding thumbnail is also deleted.

Viewing My Card (M 8–4)

You can register and edit your own information in the Phonebook as with other Phonebook entries.

“Call Manager” → “My Card”

Copying Phonebook Entries between SIM/USIM Card and Handset

“Call Manager” → “Advanced” → “Copy All Entries”

1. Select “From SIM to Handset” or “From Handset to SIM”.

Note



- When you insert the SIM/USIM card into your phone for the first time and start the Phonebook application, the confirmation screen is displayed automatically, asking you if you wish to copy or not. The number of Phonebook entries to be copied varies depending on the SIM/USIM capacity.
- If the memory space is not enough to save all entries, you cannot complete copying.

Dialling from the Phonebook

“Call Manager” → “Phonebook”

1. Highlight the desired entry and press .

Tip

- If more than one phone number is registered for the entry, highlight the desired phone number after step 1 and press .
- You can also dial from the details screen of the Phonebook. On the details screen, select the desired phone number and press .

Editing Phonebook Entries

“Call Manager” → ***“Phonebook”***

1. Highlight the entry you wish to edit.
2. Press [Options] and select “Edit”.
3. Modify the information.
4. Press [Save] when finished.

Assigning a Ringtone or a Ring Video Clip File to Each Entry

“Call Manager” → ***“Phonebook”***

1. Highlight the desired entry.
2. Press [Options] and select “Edit”, then select “Assign Tone/Video”.
3. Select “For Voice Call”, “For Video Calling” or “For New Message”.
4. Select “Assign Tone” or “Assign Video”.
When selecting “Assign Video”, go to step 6.
5. Select “Preset Sounds” or “Sound Gallery”.
6. Select the desired tone or video clip.
7. Press [Save] when finished.

Deleting Phonebook Entries

Deleting All Phonebook Entries

“Call Manager” → ***“Advanced”*** → ***“Delete All Entries”***

1. Select “Handset Entries” or “SIM Entries”.
2. Enter your handset code.

The default handset code is “9999”. For details on changing the handset code, see “To Change the Handset Code” on page 112.

Deleting a Phonebook Entry

“Call Manager” → ***“Phonebook”***

1. Highlight the desired entry.
2. Press [Options] and select “Delete”.

Manage Group (M 8–2)

Different ringtones can be set for each group. If you do not change a group ringtone, the ringtone assigned in the Settings menu is used.

“Call Manager” → “Manage Group”

1. Highlight the desired group.
2. Press [Options] and select “Assign Tone/Video”.
3. Select “For Voice Call”, “For Video Calling” or “For New Message”.
4. Select “Assign Tone” or “Assign Video”.
5. Select “Preset Sounds” or “Sound Gallery”.
6. Select the desired tone or video clip.

When selecting “Assign Video”, go to step 6.
For details on selecting a ringtone or a ring video clip file in the Settings menu, see “Assigning a Ringtone” or “Assigning a Ring Video Clip File” on page 98.

Note

- You can only edit group names in the SIM/USIM card. You cannot edit the ringtone or ring video settings.

Editing the Group Name

You can edit group names to be assigned to the Phonebook entries. First, change the Phonebook displayed (p. 43).

“Call Manager” → “Manage Group”

1. Highlight the desired group name.
2. Press [Options] and select “Edit Name”.
3. Modify the name.

Message Groups (M 8–5)

You can create a mailing list to send the same message to a group of recipients at once. Up to 5 groups can be registered.

Creating a New Mailing List

“Call Manager” → “Message Groups” → “Add New Group”

1. Enter the group name.

The new group name is displayed following the last group on the Group List screen.

Adding Recipients to a Group

Up to 20 recipients can be registered in each list.

“Call Manager” → **“Message Groups”**

1. Select the desired group name.
2. Select “Assign New Entry”.
3. Select the desired entry.
The detailed screen is displayed.
4. Select the desired phone number or Email address.

Tip

- If you modify the entry assigned in the group, you need to reassign it to the group. Press [Options] and select “Reassign Entry” in step 2.
- To remove an entry from the group, press [Options] and select “Remove Entry” in step 2.
- To remove a group, highlight a group name and press [Options] and then select “Delete” in step 1.

Sending a Message Using a Mailing List

“Call Manager” → **“Message Groups”**

1. Highlight the desired group name.
2. Press [Options] and select “Create Message”.
3. Select the desired type of messaging.

For further procedures, see “Creating a New Message” on page 56.

Memory Status

This function helps you to check the memory used in the Phonebook.

“Call Manager” → **“Advanced”** → **“Memory Status”**

Speed Dial List (M 8–3)

You can set a maximum of 8 phone numbers in the Speed Dial list (p. 23).

Setting Phonebook Entries in the Speed Dial List

“Call Manager” → **“Phonebook”**

1. Select the desired entry.
2. Highlight the desired phone number.
3. Press [Options] and select “Add to Speed Dial”.
4. Select the desired location.

Tip

- The nine digit keys correspond to list numbers.

To Edit the Speed Dial List

“Call Manager” → “Speed Dial List”

1. Highlight the entry you wish to edit.
2. Press [Options] and select “Re–Assign” (or “Assign”).

Sending a Phonebook Entry

“Call Manager” → “Phonebook”

1. Highlight the desired entry.
2. Press [Options] and select “Send Phonebook”.
3. Select “As Message” or “Via Bluetooth”.

For “As Message”

For details, see “MMS” on page 56.

For “Via Bluetooth”

For details, see “Bluetooth” on page 115.

Receiving a Phonebook Entry

When the phone receives a Phonebook entry, a confirmation message is displayed in standby.

1. Press [Yes].

The received entry is saved in the Phonebook. Press [No] to reject.

Tip

- For details on entering Bluetooth wireless settings, see “Connectivity” on page 115.

Sending a Voice Clip Message or Video Clip Message Using an Address from the Phonebook

“Call Manager” → “Phonebook”

1. Select the desired entry including the phone number or Email address you wish to use.
2. Highlight the desired phone number or Email address.
3. Press [Options] and select “Create Message”.
4. Select “Voice Message” or “Video Message”.

For further procedures, see “Creating a New Message” on page 56.

Camera (M 5)

Your phone has a built-in digital camera that allows you to take pictures and record video clips wherever you are. This section starts with basic functions and operational procedures to take, save and send pictures and video clips, followed by common and unique functions to camera and video modes.

Taking Pictures

“Camera”

1. Press  to take the picture.

The shutter sounds and the still image of the taken picture is displayed.

2. Press [Save].

The taken picture is saved in Gallery.

To cancel, press [Cancel].

To send the taken picture, press  in step 2.



Note

- When the video camera is launched, press [Options] and select “Go to Photo Camera”, or press .
- When you try to send the picture that has too large a file size, the picture size is resized for the message. The original sized picture is saved in Gallery.

Taking a Self-Portrait

You can take a self-portrait while looking at the main display.

“Camera”

1. Press [Options] and select “Switch to Int. Camera”.
Or press  in the viewfinder mode.
2. Press  to take the picture.
3. Press [Save].

The taken picture is saved in Gallery.

To return to the external camera, press [Options] and select “Switch to Ext. Camera” or press  in the viewfinder mode.



Recording Video Clips

You can record a video clip with your phone.

Recording Video Clips

“Camera”

The preview is displayed on the screen.

1. Press .
2. To stop recording, press .
3. Select “Save”.

The video clip is saved in Gallery.

To view the preview before saving, select “Preview”.

To send the video clip, select “Save and Send”. Then select the desired way you wish to send. For further procedures, see “Creating a New Message” on page 56.



Note

- You can only send video clips when “For Message” is selected for the recording time. For details, see “Selecting the Recording Time” on page 54.

Common Functions in the Photo and Video Camera Modes

Using the Digital Zoom Function

To Adjust the Zooming Ratio

1. In the viewfinder mode, press  or .

Once the phone has returned to standby, the zoom settings return to default.

Adjusting the Exposure

“Camera” → [Options] → “Exposure”

1. Press  (Bright) or  (Dark).

     : (Bright → Normal → Dark)

Once the phone has returned to standby, the brightness settings return to default.

Using the Self-Timer

Select the appropriate option.



“Camera” → **[Options]** → **“Modes”** → **“Self-timer”**
(Photo Camera Mode)

“Camera” → **[Options]** → **“Self-timer”** **(Video Camera Mode)**

1. Select “On” or “Off”.

“” is displayed on the screen when you select “On”.

Switching between the Photo and Video Camera Modes

You can switch between the photo and video camera modes by pressing  or .

Select the appropriate option.

“Camera” → **[Options]** → **“Go to Video Camera”**

“Camera” → **[Options]** → **“Go to Photo Camera”**

Selecting the Picture or Video Quality

Select the appropriate option.

“Camera” → **[Options]** → **“Picture Quality”**

“Camera” → **[Options]** → **“Video Quality”**

1. Select the desired picture or video quality.

: Super Fine

: Fine

: Normal

Note

- The better quality you select, the larger file size is needed.

Selecting the Storage Memory

Select the appropriate option.

“Camera” → **[Options]** → **“Settings”** → **“Save New Pictures”**

“Camera” → **[Options]** → **“Settings”** → **“Save New Videos”**

1. Select the desired location from “To Handset Memory”, “To Memory Card” or “Choice”.

Note

- If you select “Choice”, select the desired location every time you save.

Auto Save

You can set the phone to save pictures and video clips automatically.

“Camera” → **[Options]** → **“Settings”** → **“Auto Save”**

1. Select “On” or “Off”.

Using the Help Function

“Camera” → [Options] → “Help”

Common Shortcut Keys

If multiple options exist, they switch each time you press each following key.

	Photo Camera	Video Camera
	Max Zoom/Min Zoom	
	Change External Camera/Internal Camera	
	Save New Pictures to	Save New Videos to
	Picture Size	
	Scene	Microphone On/Off
	Picture Quality	Video Quality
	Self-Timer On/Off	
	Exposure	
	Switches Viewfinder	Switches Screen

Note

- The “Switches Screen” option is available in “Preview” before you save a video clip. See “Recording Video Clips” on page 50.

Functions in the Photo Camera Mode

Selecting the Picture Size

You can select the size of pictures. All taken pictures are saved in the JPEG format.

“Camera” → [Options] → “Picture Size”

1. Select the desired size.

(External Camera) 1200 × 1600 dots/960 × 1280 dots/
768 × 1024 dots/480 × 640 dots/
240 × 320 dots/120 × 160 dots
(Internal Camera) 240 × 320 dots/120 × 160 dots

Selecting the Scene

You can select the appropriate mode by scene when you take the picture.

“Camera” → [Options] → “Modes” → “Scene”

1. Select the desired scene.

The following four modes are available:

“Automatic” (A): Automatically adjusted to surroundings.

“Night” (🌙): Suited for night photography.

“Sports” (🏃): Suited for moving objects.

“Characters” (👤): Suited for high-contrast subjects such as text.

Selecting the Picture Effects

You can take a picture with special effects.

“Camera” → [Options] → **“Modes”** → **“Camera Effects”**

1. Select the desired effects.

The following five modes are available:

- “Off”: The camera effect is cancelled.
- “Sepia”: Creates a sepia-tone image.
- “Monochrome”: Creates a black and white image.
- “Negative”: Creates a negative image.
- “Sketch”: Creates a sketch-like image with contours of objects outlined.

Note

- Images larger than 240 [W] × 320 [H] dots cannot be used.



Continuous Shoot

You can take continuous shoots in various options.



“Camera” → [Options] → **“Modes”** → **“Continuous Shoot”**

1. Select the desired mode.

The following continuous shoot modes are available:

- “Off”: The continuous shoots are cancelled.
- “4 Pictures”/“9 Pictures” ( / ): Takes 4 or 9 pictures continuously. After selecting this mode, select from three types of speed or “Manual”.
- “Overlapped” (): Overlaps continuous pictures into one picture and makes an afterimage. After selecting this mode, select “Fast” or “Normal”.

Note

- When you select “Manual” to take continuous pictures, press  manually in the desired speed.
- When the Timer and Continuous Shoot functions are simultaneously set, “ ” (for “4 Pictures”, for example) is displayed instead.
- “9 Pictures” and “Overlapped” are not available for picture sizes larger than 240 × 320 dots.

Selecting a Frame

You can select the frame from preset patterns or Picture Gallery.

“Camera” → **[Options]** → **“Modes”** → **“Add Frame”**

1. Select “Preset Frames” or “Picture Gallery”.
2. Select the desired frame.

The selected frame is confirmed on the display.

3. Press .

Note

- Images larger than 240 [W] × 320 [H] dots cannot be used.

Using the Full Screen

You can display the preview on the full screen without the soft key area and indicator area.

“Camera” → **[Options]** → **“Settings”**

1. Select “Full Viewfinder”.

To return to the normal viewfinder, select “Normal Viewfinder”.

Selecting the Shutter Sound

“Camera” → **[Options]** → **“Settings”** → **“Shutter Sound”**

1. Select the desired shutter sound from 3 preset patterns.

Note

- *Continuous Shoot* uses the specialised shutter sound that cannot be changed from the above settings.
- The shutter sound remains active even when “Ringer Volume” (p. 97) is set to “Silent” to prevent unauthorised use.

Functions in the Video Camera Mode

Selecting the Recording Time

“Camera” → **[Options]** → **“Record Time”**

1. Select “For Message” or “Extended Video”.

For Message (): Limits the size to send a message depending on service providers.

Extended Video (): Less than 30 minutes (depending on the memory).

2. Select “Large(QCIF)” or “Small(SubQCIF)” video format for “For Message” and “QVGA(asf)”, “Large(QCIF)” or “Small(SubQCIF)” format for “Extended Video”.

Note

- If you select “For Message” for the recording time, the file size is limited depending on the service provider. Therefore, the quality is also limited for the setting.
- “Save and Send” is not displayed after recording in the Extended Video mode.

Recording Video Clips with the Sound

To record a video clip with the sound, the microphone needs to be activated.

“Camera” → **[Options]** → **“Settings”** → **“Microphone”**

1. Select “On” or “Off”.

Note

- The microphone is already turned on in the default setting. Select “Off” to record a video clip without the sound.
- The file size of a video clip can be reduced if the sound is not recorded.

Video Encoding

“Camera” → **[Options]** → **“Settings”** → **“Video Encode”**

1. Select the appropriate format.

Messages (M 4)

Your phone allows you to send and receive text, multimedia and Email, and receive WAP alerts as well.

SMS

SMS allows you to send text messages up to 765 characters long. If you send a message of more than 160 characters, it is split into several segments.

MMS

MMS allows you to send and receive multimedia messages of up to 300 KB with images, sound, or video clips attached.

Email

Email allows you to send messages of up to 300 KB.

Note

- *Some MMS functions may not always be available depending on your network. Contact your network operator for more information.*
- *Maximum message size varies depending on the settings by the network operator.*

Creating a New Message (M 4–1)

(SMS/MMS)

 → **“Create Message”** → **“Message”**

(Email)

 → **“Create Message”** → **“E-mail”**

1. Select the address field.
2. Select the desired method to enter the address.
3. For MMS, enter or select the Email address or phone number from the Phonebook list. For SMS, enter or select a phone number. For Email, enter or select an Email address.
 - To add multiple Email addresses or phone numbers, highlight the recipient field, press [Options], select “Edit Recipients”, then select “Add Recipient”. Enter or select the Email address or phone number from the existing Phonebook.
 - To change the recipient types, press [Options], select “Edit Recipients” and highlight the desired recipient. Press [Options] and select “Change to CC” or “Change to BCC”.
 - To add a subject, press [Options] and select “Add Subject”.
4. Place the cursor in the message field.
5. Enter the message.

6. Highlight the “Send” indicator in the lower left of the screen. Press  and select “Send Message”.

After the message is sent, the message is moved to the Sent box.

Tip

- *To send the same message to a group of recipients, select “Select Message Group” in step 2, then select the desired group name. For details on creating a mailing list, see “Creating a New Mailing List” on page 46.*

To Add a Slide Show

1. In step 5 in “Creating a New Message” on page 56, press [Options] and select “Add Slide”.

If you wish to add more slides, select “Add Slide Before” or “Add Slide After”.

2. Enter the message.

If you wish to set the duration of each slide, press [Options] and select “Slide Duration”, then select the desired duration.

Tip

- *You can create messages up to 300 KB. Each slide can contain one picture and/or one sound file or video clip.*

To Remove or Replace Attachments

1. In step 5 in “Creating a New Message” on page 56, press [Options] and select the corresponding remove option for each attachment.

To Attach Gallery Data

1. In step 5 in “Creating a New Message” on page 56, highlight the “Picture”, “Sound” or “Video” indicator in the lower centre of the screen, and press .
2. Select “Saved Picture Gallery”, “Saved Sound Gallery” or “Saved Video Gallery”.
3. Select the desired file.

If you wish to take new pictures, record sounds or video clips, select “Take Picture”, “Record Sound” or “Record Video”.

- For attached pictures, select the appropriate resize option, as the maximum message size for sending varies depending on the network operator.

To Attach a Phonebook Entry

1. In step 5 in “Creating a New Message” on page 56, highlight the “Others” indicator in the lower right of the screen. Press **O** and select “Attach Phonebook”.
2. Select the desired entry.
If you wish to select your own Phonebook entry, select “My Card”.
3. Select the desired field.
The selected information is entered.

To Attach a Schedule Entry

1. In step 5 in “Creating a New Message” on page 56, highlight the “Others” indicator in the lower right of the screen. Press **O** and select “Attach Appointment”.
2. Select the desired day including a schedule entry you wish to add.
3. Select the desired schedule entry.

Using the Sending Options

You can use the message sending options for each type of message.

1. Highlight the “Send” indicator in the lower left of the screen. Press **O** and select “Messaging Settings”.
 - “Read Report” (“On”, “Off”) (MMS): Confirms whether or not a report is sent notifying the sender that the message has been read.
 - “Delivery Report” (“On”, “Off”) (SMS/MMS): Enables or disables Delivery Report when the message is successfully sent to the recipient.
 - “Expiry Time” (“Maximum”, “30 minutes”, “1 hour”, “6 hours”, “1 day”, “1 week”) (SMS/MMS): Sets Expiry Time for a message to be saved in the server.
 - “Priority” (“High”, “Normal”, “Low”): Prioritises composed messages.
 - “Delivery Time” (“No delay”, “30 minutes”, “1 hour”, “6 hours”, “1 day”, “1 week”) (MMS): Sets the time the message is delivered after the Send key is pressed.
2. Highlight the “Send” indicator in the lower left of the screen. Press **O** and select “Send Message”.
After the message is sent, the message is moved to the Sent box.

Note

- The current message size displayed while you are creating the message is an approximation.
- If a message cannot be sent for some reason, the message stays in the Outbox and the “✉” is displayed in standby.

Tip

- To save the message without sending, press [Options] and select “Save to Drafts” in step 5 in “Creating a New Message” on page 56.
- You can send the following items attached to multimedia messages. Details are given in the following sections.
 - Gallery data
 - Phonebook entry
 - File (Schedule entry created by Calendar, Phonebook entry), etc.
- You can use the template option to help you compose messages. For details on using this option, see “Using Templates” on page 41.

Sending a Message in the Drafts Box (M 4–4)

 → “Drafts”

1. Select the desired tab, SMS/MMS or Email.
2. Press [Options] and select “Edit & Send”.
3. Modify the message, if necessary.
4. Highlight the “Send” indicator in the lower left of the screen. Press  and select “Send Message”.

Reading Messages

Messages you receive are saved in the Inbox.

 → “Inbox”

1. Select the message you wish to view.

Storing the Phone Number of a Sender in the Phonebook

 → “Inbox”

1. Highlight the message from which you wish to store the phone number or Email address.
2. Press [Options] and select “Save Address”.

The new Phonebook entry screen including the phone number is displayed. For details on creating a new Phonebook entry, see “Add New” on page 43.

Calling the Phone Number of a Sender Embedded in the Message

 → **“Inbox”**

1. Highlight the message including the phone number you wish to dial.
2. Press [Options] and select “Call Sender”.

Downloading a Single MMS

 → **“Inbox”**

1. Highlight the message alert () you wish to download.
2. Press [Options] and select “Download”.

Tip

- You can download multiple messages at the same time. See “Downloading Multiple MMS”.

Downloading Multiple MMS

 → **“Inbox”**

1. Press [Options] and select “Advanced”.
2. Select “Multiple Select”.
3. Select the desired message alert using the “Select” or “Select All” option.
4. Select “Download”.

The selected messages are downloaded at the same time.

Replying to a Message or to All Addresses

 → **“Inbox”**

1. Highlight the message the sender of which you wish to reply to.
2. Press [Options] and select “Reply” or “Reply all”.
3. Select “Reply” or “Reply with History”.
4. Enter the message.
5. Highlight the “Send” indicator in the lower left of the screen. Press  and select “Send Message”.

Forwarding a Message

 → **“Inbox”**

1. Highlight the message you wish to forward.
2. Press [Options] and select “Forward”.
3. Perform steps 1 to 5 in “Creating a New Message” on page 56.

Sorting the Messages in the List

 → ***“Inbox”***

1. Press [Options] and select “Advanced”.
2. Select “Sort”.
3. Select the desired sort type.

Locking or Unlocking the Messages

 → ***“Inbox”***

1. Highlight the message you wish to lock or unlock.
2. Press [Options] and select “Advanced”.
3. Select “Lock” or “Unlock”.

Cell Broadcasts (M 4–9)

You can receive cell broadcast messages or general messages such as weather forecasts and traffic reports. This information is broadcast to subscribers in certain network areas.

This function may not be available on all mobile phone networks. Contact your network operator for more information.

Enabling/Disabling Cell Broadcasts

 → ***“Cell Broadcasts”*** → ***“Switch On/Off”***

1. Select “On” or “Off”.

Reading Cell Broadcast Messages

 → ***“Cell Broadcasts”*** → ***“Read Messages”***

1. Select the desired subject.
2. Scroll the screen to read the message.
3. Press [Back].

Setting Languages for Cell Broadcast Messages

 → ***“Cell Broadcasts”*** → ***“Settings”*** → ***“Language”***

The current language is displayed.

1. Press .
2. Press to check.
3. Press [Save].

Subscribing to Cell Broadcasts

Select the page of the cell broadcast message that you want.

 → ***“Cell Broadcasts”*** → ***“Settings”*** → ***“Set Info Subjects”*** → ***[Options]***

1. Select “Add/Remove”.
2. Select the desired page.
3. Press [Back].

Tip

- If the desired page is not in the list that appears in step 2, select “Create Subject” in step 1, then enter the subject code to add a page. For details on the subject code, contact your service provider.

Area Info (M 4–10)

The Area Info is the message information that operators send to subscribers in certain areas.

When you receive Area Info, the message (area code) is displayed in standby.

Enabling/Disabling Area Info

 → “Area Info”

1. Select “On” or “Off”.

Note

- This function may not be available on all mobile phone networks. Contact your network operator for more information.
- If Area Info is set to “On”, the standby time will decrease.

Messaging Settings (M 4–11)

General Settings

 → “Messaging Settings” → “General Settings”

1. Select the item you wish to set up.

- “Home Download”:
Controls message download timing inside your network area.
- “Always Download”:
Downloads messages immediately from the server.
- “Always Defer”:
Defers message download.
- “Roaming Download”:
Controls message download timing when roaming outside of your network.
- “Always Download”:
Downloads messages immediately from the server.
- “Always Defer”:
Defers message download.
- “Delivery Report”:
Enables or disables Delivery Report request.
- “Read Report”:
Enables or disables Read Report request.

- “Expiry Time”:
This indicates the number of days and hours for which a message you send may remain undelivered to the message recipient. During this period, the message service centre will continually try to deliver the message to the recipient.
- “Delivery Report Allow”:
Confirms whether or not a report is sent notifying the sender when you receive an MMS.
- “Read Report Allow”:
Enables or disables Read Report Allow when the recipient is required to inform the sender that the message has been read.
- “Edit Signature”:
Opens the screen to enter the signature.
- “Auto Delete”:
Deletes the oldest message automatically, when the Inbox, Sent or both (Inbox and Sent) is full.
- “Automatic Resend”:
Tries to resend the failed SMS/MMS message up to two times (“On” or “Off” selection).
- “Message List View”:
Switches the mailbox listing between “One-line View” and “Two-line View”.

SMS Settings

 → “**Messaging Settings**” → “**SMS Settings**”

1. Select the item you wish to set up.

- “Message Centre”:
Enter the message centre number.
If you wish to enter a country code for a message to an international number, long press  until a + sign is displayed.
- “Message Format”:
Select the message format to be used when creating a new message.
- “Reply Path”:
Accepts or rejects the same reply path with the send path when receiving the reply message for your message.

MMS Settings

☐ → **“Messaging Settings”** → **“MMS Settings”**

1. Select the item you wish to set up.
 - **“MMS Accounts”**:
Select the desired account or select **“Create New”** to enter the following settings.
“Profile Name”: MMS profile name (Unique name)
“Proxy”: Proxy setting for MMS
“Relay Server URL”: MMS relay server
 - **“Slide Duration”**:
Sets the duration of the slide.
 - **“Max Message Size”**:
Defines the maximum size of downloaded and created MMS messages.
 - **“Creation Mode”**:
When set to **“Free”**, you can attach files of any format to the mail. When set to **“Restricted”**, only certain formats can be attached.

E-mail Settings

☐ → **“Messaging Settings”** → **“E-mail Settings”**

1. Select the item you wish to set up.
 - **“Email Accounts”**:
Select the desired account or select **“Create New”** to enter the following settings.
“Account Name”: Email account name (Unique name)
“POP3 Server”: Server name, user ID, password and port number for POP3 server
“SMTP Server”: Server name, user ID, password, port number for SMTP server and SMTP Authentication
“Access Point”: Access point for Email
“E-mail Address”: E-mail address
 - **“Download Interval”**:
Sets the download interval.
 - **“Max Message Size”**:
Defines the maximum size of downloaded and created MMS messages.

Browser (M 2)

Your phone is already configured to access SmarTone *iN!* and the mobile internet.

SmarTone *iN!* is a new mobile internet portal which is your gateway to a new world of information, games, music and services.

Because your phone uses 3G (UMTS), it has a system that is faster than previous ways of getting mobile information. Also, the connection is 'always on' which means there is no need to wait for dialling up. You only have to pay for the data you send or receive, not how long you're connected.

Your phone contains a WAP browser used for surfing on the Mobile Internet, where you can get a lot of useful information. Normally, pages are designed for a mobile phone.

Your phone is already setup to SmarTone *iN!* site for WAP/MMS Settings.

Main Menu

"Browser" → "Homepage"

The SmarTone *iN!* service page is displayed.

"Browser" → "Go to URL"

The URL entry screen is displayed, allowing you to jump to a site.

"Browser" → "Bookmarks"

See page 66.

"Browser" → "Alert Inbox"

WAP Push alerts are displayed.

"Browser" → "My Saved Page"

The saved screenshots are displayed.





"Browser" → "Access History"

The history of pages you have recently browsed is displayed.

"Browser" → "Browser Settings"

See page 68.

Navigating a WAP Page

- : Move the highlights around in the screen.
- : Executes the option displayed in the lower centre of the screen.
- : Launches the browser option menu.
- : Selects an action displayed in the lower right of the screen.
Used to access “SmarTone *iN!*” by opening the browser.
-  (short press): Exits the browser.
(long press): Turns off the phone.

Editing Bookmarks

“**Browser**” → “**Bookmarks**”

1. Select the desired URL, and press [Options].

You can edit the list of Bookmarks by the following options:

- | | |
|---------------|--|
| “Open”: | Selects a bookmark. |
| “Details”: | Displays detailed information of the WAP page. |
| “Send page”: | Sends the URL address to recipients. |
| “New”: | Creates new folders or bookmarks. |
| “Rename”: | Renames bookmarks. |
| “Edit URL”: | Edits URL address of the bookmark. |
| “Move”: | Moves bookmarks to another location. |
| “Delete”: | Deletes bookmarks. |
| “Delete All”: | Deletes all bookmarks. |

The Browser Options

You can use various options of the WAP browser.

→ **[Options]**

“Select”:	Selects a WAP page.
“Home”:	Goes to the homepage.
“Alert Inbox”:	Displays WAP Push alerts.
“Bookmarks”:	(see “Editing Bookmarks” on page 66.)
“Mark Page”:	Marks the selected WAP page.
“Save This Link”:	Save the selected link.
“Save Items”:	Saves items from WAP pages.
“Go to URL”:	Goes to the WAP page that you enter the URL address.
“Access History”:	Shows the history where you have browsed.
“Forward”:	Goes to the next page of the pages displayed.
“Reload Page”:	Reloads the WAP page again to get new information.
“Advanced”:	Displays the advanced menus.
“Exit”:	Exits the browser.

The Advanced Options

→ **[Options]** → **“Advanced”**

“My Saved Page”:	Displays the bookmarked pages.
“Save This Page”:	Saves the WAP page as the local file.
“Send Page”:	Sends the WAP page data.
“Details”:	Shows detailed information of the WAP page.
“Browser Data”:	Edits the browser data. You can clear the cache/cookies/history.
“Search This Page”:	Searches specific words in the WAP page.
“Copy Text”:	Copies the text on the web page.
“Browser Settings”:	Displays the Settings menus.
“Restart Browser”:	Restarts the browser.
“About”:	Displays the browser information.

Browser Settings (M 2–7)

“Browser” → “Browser Settings”

- “Font Size”: Sets the size of the browsing font.
- “Scroll Step”: Sets the speed of scrolling.
- “Send Referrer”: Enables or disables the notification of the referrer.
- “Cookies”: Adjusts the setting of cookies.
- “Downloads”: Displays downloading data from the images/sounds/objects.
- “Security”: Adjusts the security prompt level.
- “WAP Push”: Sets whether you need confirmation for push message.
- “Download to”: Sets the download location.

Media Player (M 7)

Media Player can play sound files and video clip files.







TV & Video (M 7-1)

Playing Back Video Clip Files

“Media Player” → “TV & Video” → “Video Gallery”

1. Select “Handset Memory” or “Memory Card”.
2. Select the desired file.
To pause playback, press .
To stop playback, press [Back].

Tip

- You can control the Video Player by using the following keys:
 - : Increases or decreases the volume.
 -  (long press): Mutes.
 - : Jumps to the next file.
 - : Returns to the top portion of the current file.
 -  (long press): Fast-forwards.
 -  (long press): Rewinds.

Searching a File to Be Played Back

“Media Player” → “TV & Video” → “Video Gallery”

1. Select “Handset Memory” or “Memory Card”.
2. Select “All Videos” or the desired playlist.

3. Press [Options] and select “Search”.
4. Enter the first few letters of the title.
Search results are displayed and the matching file is highlighted.

Adding a File to the Playlist

You can create a playlist registering desired files.

“Media Player” → “TV & Video” → “Video Gallery”

1. Select “Handset Memory” or “Memory Card”.
2. Select “All Videos” or the desired playlist.
3. Highlight the file you wish to add to the playlist.
4. Press [Options] and select “Add to Playlist”.

The playlists are displayed. For details on creating a playlist, see “Adding a New Playlist” on page 70.

5. Select the desired folder.
6. Press .

The file highlighted in step 3 is saved.

To delete files from the playlist, highlight the file in the playlist and press [Options]. Then select “Delete from Playlist”.

Adding a New Playlist

“Media Player” → **“TV & Video”** → **“Video Gallery”**

1. Select “Handset Memory” or “Memory Card”.
2. Press [Options] and select “Add New Playlist”.
3. Enter the desired playlist name.
4. Press **○**.

Note

- To delete the playlist, highlight the playlist and press [Options]. Then select “Delete Playlist”.

Editing the Video Clip File

“Media Player” → **“TV & Video”** → **“Video Gallery”**

1. Select “Handset Memory” or “Memory Card”.
2. Select “All Videos” or the desired playlist.
3. Select the file you wish to edit.
4. Press [Options] and select “Edit”.
5. Select the desired option.
 - “Crop”: Select the desired area to be cropped.
 - “Subtitle”: Create a subtitle to add to the file.

Settings

You can select a play mode for “Playback Pattern”, “Backlight” and “Display Size” when playing back video clip files.

“Media Player” → **“TV & Video”** → **“Video Gallery”**

1. Select “Handset Memory” or “Memory Card”.
2. Select “All Videos” or the desired playlist.
3. Select the file for which you wish to adjust the play mode.
4. Press [Options] and select “Settings”.
5. Select “Playback Pattern”, “Backlight” or “Display Size”.
6. Select from the following:
 - “Playback Pattern”
 - “Normal”: Plays back all files in the selected folder once and stops playback.
 - “Repeat”: Continues playback in the selected folder.
 - “Repeat All”: Plays back all files in the selected folder.
 - “Random”: Plays back files in the selected folder at random.

- “Backlight”
 - “Always On”: Lit while the file is played back.
 - “Always Off”: Unlit while the file is played back even if a key is pressed.
 - “Normal Settings”: Works with the main backlight setting (p. 102).
- “Display Size”
 - “Original Size”: Displays the file in its original size.
 - “Enlarge”: Displays the file in an enlarged size.
 - “Full Screen”: Displays the file on the full screen.

SD Video

Video clips that are recorded by a video camera or downloaded from mobile Internet sites can also be managed with SD Video.

“Media Player” → “TV & Video” → “SD VIDEO”

1. Select the desired file.

To pause playback, press .

To stop playback, press .

To delete files from the playlist, highlight the playlist, press [Options] and select “Delete”.

Downloading Video Clip Files

“Media Player” → “TV & Video” → “Download Videos”

The video clip file download site is displayed.

Music Player (M 7–2)

You can play back MP3, AAC-LC and AAC+ format sound files with Music Player. While playing back sound files in the background, you can use other menus.

Playing Back Sound Files

“Media Player” → “Music Player” → “My Music”

1. Select “All Music” or the desired playlist.

2. Select the desired file.

To pause playback, press .

To stop playback press [Back].

Note

- *You are asked whether or not to play sounds when the Silent mode is activated.*
- *To play the last played file, select “Last Played Music”. “Currently Playing” is displayed when the file is being played back.*

Tip

- *You can return to the Main menu screen while playing back the file in the background.*
- *You can create your playlist selecting only the desired files (p. 73).*
- *You can select the playback pattern in step 2. Press [Options] and select “Playback Pattern”.
“Normal”: Plays back all files in the selected folder once and stops playback.*

“Repeat”: Continues playback in the selected folder.
“Repeat All”: Plays back all files in the selected folder.
“Random”: Plays back files in the selected folder at random.

- You can control the Music Player by using the following keys:

: Increases or decreases the volume.

 (long press): Mutes.

: Jumps to the next file.

: Returns to the top portion of the current file.

 (long press): Fast–forwards.

 (long press): Rewinds.

: Plays back the file in the background.

Searching a File to Be Played Back

“Media Player” → **“Music Player”** → **“My Music”**

1. Select “All Music” or the desired playlist.
2. Press [Options] and select “Search”.
3. Enter the first few letters of the title.

Search results are displayed and the matching file is highlighted.

Adding a File to the Playlist

You can create a playlist registering desired files.

“Media Player” → **“Music Player”** → **“My Music”**

1. Select “All Music” or the desired playlist.
2. Highlight the file you wish to add to the playlist.
3. Press [Options] and select “Add to Playlist”.

The playlists are displayed. For details on adding a playlist, see “Adding a New Playlist” on page 73.

4. Select the desired folder.
5. Press .

The file highlighted in step 2 is saved.

Adding a New Playlist

“Media Player” → “Music Player” → “My Music”

1. Press [Options] and select “Add New Playlist”.
2. Enter the desired playlist name.
3. Press .

To delete the playlist, highlight the playlist and press [Options]. Then select “Delete Playlist”.

Downloading Music Files

“Media Player” → “Music Player” → “Download Music”

The music file download site is displayed.

Note

- *This service is not available with some service providers. Please contact your service provider for more information.*

Gallery (M 6)

Gallery contains several types of picture, sound and video clip data. Also included in Gallery are frequently used text message phrases and accessed WAP pages (addresses) which you can use. You can also transmit picture, sound and video clip data via *Bluetooth* wireless technology to OBEX-enabled phones.

Picture Gallery (M 6–1)

Pictures that are taken by a digital camera or images that are downloaded from mobile Internet sites can be managed. You can register pictures in the following formats: JPEG, PNG, WBMP and GIF.



Viewing Pictures

“Gallery” → “Picture Gallery”

1. Select the file you wish to view.
The selected picture is displayed.

Switching the Memory Source

“Gallery” → “Picture Gallery”

1. Select the file you wish to view.
The selected picture is displayed.
To display the list from the memory card, press .
To go back to the handset memory, press .

Using Images as Wallpaper

“Gallery” → “Picture Gallery”

1. Highlight the file you wish to use as wallpaper.
2. Press [Options] and select “Set as Wallpaper”.

Saving an Image to Phonebook Entries

You can use this option only for pictures saved in the handset memory.

“Gallery” → “Picture Gallery”

1. Highlight the file you wish to add to Phonebook.
2. Press [Options] and select “Save to phonebook”.
To overwrite, select the data you wish to save.
To save as a new entry, select “As New”.
For details on entering a name, see “Add New” on page 43.

Editing Pictures

“Gallery” → “Picture Gallery”

1. Highlight the file you wish to edit.
2. Press [Options] and select “Picture Editor”.
3. Select the desired option.

Note

- “Picture Editor” may not be available depending on the original picture and copyright issued.

Adjusting the Size

You can adjust the picture to an appropriate size depending on the scene.

“Gallery” → “Picture Gallery”

1. Highlight the file you wish to adjust the size of.
2. Press [Options] and select “Resize”.
3. Select the desired option.

Note

- “Resize” may not be available depending on the original picture and copyright issued.

Tip

- For other option menus, see “Common Option Menus” on page 77.

Downloading Picture Files

“Gallery” → “Picture Gallery” → “Download More”

The picture file download site is displayed.

Video Gallery (M 6–2)

Video clips that are recorded by a video camera or video clips that are downloaded from mobile Internet sites can be managed.

Playing Back Video Clip Files

“Gallery” → “Video Gallery”

1. Select the file you wish to play back.
2. Press .

To pause playback, press .

To resume, press  again.

To stop playback, press [Back].

To display the list from the memory card, press .

To go back to the handset memory, press .

Using a Video Clip as a Ring Video

You can set your video clip to play back when the phone rings.

“Gallery” → **“Video Gallery”**

1. Highlight the desired video clip.
2. Press [Options] and select “Set as Ring Video”.

Tip

- For other option menus, see “Common Option Menus” on page 77.

Downloading Video Clip Files

“Gallery” → **“Video Gallery”** → **“Download More”**

The video clip file download site is displayed.

Sound Gallery (M 6–4)

The downloaded sound files and the AMR data recorded by Voice Recorder are managed in Sound Gallery. The default ringtones are not contained within Sound Gallery. Only the sound files you can play back with the phone are stored in Sound Gallery.

Playing Back Sound Files

“Gallery” → **“Sound Gallery”**

1. Select the file you wish to play back.
To stop playback, press .

Note

- This option may not be available in all regions.

Switching the Memory Source

“Gallery” → **“Sound Gallery”**

1. Press .

The tab switches and the list is displayed from the memory card. To go back to the handset memory, press .

2. Select the desired sound file.

Using the Sound Files as a Ringtone

“Gallery” → **“Sound Gallery”**

1. Highlight the file you wish to use as a ringtone.
2. Press [Options] and select “Set as Ringtone”.

Note

- AMR format music files cannot be used for ringtones.

Tip

- For other option menus, see “Common Option Menus” on page 77.

Other Documents (M 6–7)

Some types of files are stored in the Other Documents folder of the phone. You can edit and use these files as Gallery data.

Opening the Document File

“Gallery” → **“Other Documents”**

1. Select the desired file.

Tip

- For other option menus, see “Common Option Menus”.

Common Option Menus

Activating Files with Copyright Protection (DRM)

Some pictures, sound files, and video clips have a digital copy protection program, which is called DRM (Digital Rights Management). You need to activate the digital licence permission to open the files. Files protected with DRM are displayed with .

Select the appropriate option.

“Gallery” → **“Picture Gallery”**

“Gallery” → **“Video Gallery”**

“Gallery” → **“Sound Gallery”**

“Gallery” → **“Other Documents”**

1. Highlight the file you wish to activate.
2. Press [Options] and select “Activate”.

Note

- Some pictures with DRM may not open even when an attempt is made to activate it.

Sending Gallery Data

Select the appropriate option.

“Gallery” → **“Picture Gallery”**

“Gallery” → **“Video Gallery”**

“Gallery” → **“Sound Gallery”**

“Gallery” → **“Other Documents”**

1. Highlight the desired file.
2. Press [Options] and select “Send”.
3. Select “As Message” or “Via Bluetooth”.

For details on creating a message, see “Creating a New Message” on page 56.

For details on *Bluetooth* wireless settings, see “Bluetooth” on page 115.

Note

- Pictures/Sounds/Video clips protected by copyright cannot be sent attached to a message, with the exception of *Separate Delivery* files.
- When pairing, you need to enter your passcode when establishing contact with a Bluetooth wireless technology enabled device for the first time.

Receiving Gallery Data

When the phone receives Gallery data, a confirmation message is displayed in standby.

1. Press [Yes].

The received data is saved in the corresponding Gallery folder.

Tip

- For details on Bluetooth wireless settings, see “Connectivity” on page 115.

Using Gallery Data

You can copy, move, sort, rename, and delete the saved Gallery data.

Select the appropriate option.

“Gallery” → **“Picture Gallery”**

“Gallery” → **“Video Gallery”**

“Gallery” → **“Sound Gallery”**

“Gallery” → **“Other Documents”**

1. Highlight the desired file.
2. Press [Options] and select “Advanced”.
3. Select the desired option.

“Move”:	Moves files to another folder. Select the desired folder to move to.
“Copy”:	Copies files. Select the desired folder to copy to.
“Create Folder”:	Creates a new folder.
“Multiple Select”:	Selects multiple files.
“Sort”:	Sorts the file. Select the desired files to sort.

To Rename the File

Select the appropriate option.

“Gallery” → **“Picture Gallery”**

“Gallery” → **“Video Gallery”**

“Gallery” → **“Sound Gallery”**

“Gallery” → **“Other Documents”**

1. Highlight the desired file.
2. Press [Options] and select “Rename”.

To Delete the File

“Gallery” → **“Picture Gallery”**

“Gallery” → **“Video Gallery”**

“Gallery” → **“Sound Gallery”**

“Gallery” → **“Other Documents”**

1. Highlight the desired file.
2. Press [Options] and select “Delete”.

To See the Gallery Details

Select the appropriate option.

“Gallery” → **“Picture Gallery”**

“Gallery” → **“Video Gallery”**

“Gallery” → **“Sound Gallery”**

“Gallery” → **“Other Documents”**

1. Highlight the file you wish to view the details of.
2. Press [Options] and select “Details”.

Selecting Multiple Files

You can select more than one item from Gallery for moving, copying and deleting.

Note

- *The following procedure applies when the entries other than “Download More” are highlighted.*

Select the appropriate option.

“Gallery” → **“Picture Gallery”** → [Options]

“Gallery” → **“Video Gallery”** → [Options]

“Gallery” → **“Sound Gallery”** → [Options]

“Gallery” → **“Other Documents”** → [Options]

1. Select “Advanced”.
2. Select “Multiple Select”.
3. Press to check the desired file names.
4. Press [Options] and select the desired option.

Tip

- *To remove the check, select the file again or select “Unselect” in step 4.*
- *If you wish to select all files, select “Select All” in step 4. To unselect all, select “Unselect All”.*

Text Templates (M 6–6)

You can register up to 50 text templates for use in text messages and multimedia messages. The maximum capacity of the text templates is 100 KB.

Adding Phrases to Text Templates

“Gallery” → “Text Templates” → “Add New Template”

1. Enter the text and press .

Editing Text Templates

“Gallery” → “Text Templates”

1. Highlight the text template you wish to edit.
2. Press [Options] and select “Edit”.
To view the text template, press [Options] and select “View”.
To delete the text template, press [Options] and select “Delete”.
3. Modify the text and press .

Sending Text Templates

“Gallery” → “Text Templates”

1. Highlight the text template you wish to send.
2. Press [Options] and select “Send Template”.

Memory Status (M 6–8)

This function helps you to check the memory status of the handset memory or memory card. Memory status covers the following.

Handset Memory: Applications, Pictures, Videos, Sounds, Others, Total and Free

Memory Card: Pictures, Videos, Sounds, Others, Total and Free

“Gallery” → “Memory Status”

1. Select “Handset Memory” or “Memory Card”.

Games & Applications (M 1)

GSX™ & Java™ Gallery (M 1–1)

The list of Java™ applications is displayed.

Downloaded applications are displayed in order starting from the latest one.

Executing Applications

“Games & Applications” → “GSX™ & Java™ Gallery”

Downloaded applications are sequentially displayed from the latest one.

1. Select the title of the application you wish to execute.
The selected application is executed. When using network connection type applications, connection to the network can be selected.
2. To end the application, press  and select “End”.

Setting a Screensaver Application



“Games & Applications” → “GSX™ & Java™ Gallery”

1. Highlight the desired screensaver application.
2. Press .
3. Press [Yes].

The confirmation screen to set a screensaver is displayed.

Downloading Applications

“Games & Applications” → “GSX™ & Java™ Gallery” → “Download More”

1. Select the application you wish to download.
The confirmation screen is displayed after various WAP browser screens.
2. Press  to start downloading.
3. Press  when finished.

Setting Permission

You can set permission for selected Java™ applications.

“Games & Applications” → “GSX™ & Java™ Gallery”

1. Highlight the desired Java™ application.
2. Press [Options] and select “Permission”.
3. Select one of the following options:

“Phone Call”:	Sets permission to make voice calls.
“Network Access”:	Sets permission to access the network.
“Messaging”:	Sets permission to perform MMS and SMS messaging.
“Autorun”:	Sets permission to perform the Autorun function.
“Local Connection”:	Sets permission to access local contents.
“Read User Data”:	Sets permission to read user data, such as Phonebook entries, mailbox (Inbox) and Gallery data.
“Write User Data”:	Sets permission to write entries in your phone, such as Phonebook entries, mailbox (Inbox) and Gallery data.
“Use Multimedia”:	Sets permission to use the multimedia recording.
“Reset”:	Clears all the above settings.

4. Select one of the following options:

“Session”:	The confirmation message is not displayed until you exit the application, while execution of the API of the specified function group is authorised.
“Ask Once”:	The confirmation message is displayed every time the API of the specified function group is executed.
“No”:	Execution of the API of the specified function group is not authorised.

Note

- To clear all the permission settings, select “Reset” in step 3.
- All permissions are not available for all Java™ applications.

Setting Network Access

In order to allow Java™ applications to access to the network, you need to set the network access.

“Games & Applications” → “GSX™ & Java™ Gallery” → [Options] → “Permission” → “Network Access”

1. Select “Session”, “Ask Once” or “No”.

Viewing Application Information

You can check the information of Java™ applications.

“Games & Applications” → “GSX™ & Java™ Gallery”

1. Highlight the desired Java™ application.
2. Press [Options] and select “Information”.

Deleting an Application

You can delete an application from the handset memory.

“Games & Applications” → “GSX™ & Java™ Gallery”

1. Highlight the desired Java™ application.
2. Press [Options] and select “Delete”.

Set Java™ Wallpaper (M 1–2)

You can set Java™ Wallpaper for the standby screen.

Switching the Java™ Wallpaper On or Off

“Games & Applications” → “Set Java™ Wallpaper” → “Switch On/Off”

1. Select “On” or “Off”.

Set Application

“Games & Applications” → “Set Java™ Wallpaper” → “Set Application”

The downloaded applications are displayed.

1. Select the desired Java™ Wallpaper.





Java™ Settings (M 1–3)

Application Volume

You can set the volume of the application such as the sound effect to one of the five levels or silent. When the profile is set to “Silent”, the “General Volume” setting (p. 97) has priority.

“Games & Applications” → **“Java™ Settings”** → **“Application Volume”**

The current volume level is displayed.

1. Press  (or ) to increase the volume or press  (or ) to decrease the volume and then press .

Backlight

“Games & Applications” → **“Java™ Settings”** → **“Backlight”** → **“Switch On/Off”**

1. Select “Always On”, “Always Off” or “Normal Settings”.
 - “Always On”: Lights while the application is operated. Blinks when the blink setting is on.
 - “Always Off”: Turns off while the application is operated even if a key is pressed.
 - “Normal Settings”: Works with the main backlight setting (p. 102). Blinks when the blink setting is on.

To Set the Blinking Operation

This setting enables the backlight to be controlled by the application. If set to “Off”, the backlight cannot be turned on from the application.

“Games & Applications” → **“Java™ Settings”** → **“Backlight”** → **“Blink”**

1. Select “On” or “Off”.

Vibration

When the vibrator is set in the application, you can choose whether the operation is enabled or not.



“Games & Applications” → **“Java™ Settings”** → **“Vibration”**

1. Select “On” or “Off”.

Calls & Alarms

You can set the priority of incoming calls and alarms while an application is operating.

“Games & Applications” → “Java™ Settings” → “Calls & Alarms”

1. Select “Voice Call”, “Video Calling”, “Incoming Message” or “Alarm”.
2. Select the desired method.
 - “Call Priority”, “Message Priority” or “Alarm Priority”:
The application is suspended automatically, and you can receive a call or a message, or the alarm will sound. After finishing the call or the message, or the alarm ends, the suspend indicator () is displayed letting you know there is a suspended application.
 - “Call Notice”, “Message Notice” or “Alarm Notice”:
The marquee (character scrolls) is displayed on the first line of the screen while the application continues. If you press , the application is suspended, and you can receive a call or a message. After finishing the call or the message, the suspend indicator () is displayed letting you know there is a suspended application.

Java™ Information (M 1–4)

The information about the licences belonging to Java™ is displayed.

Organiser (M 3)

Calendar (M 3–1)

Calendar allows you to easily schedule appointments or events at any given date or time.

These entries can also be sent via *Bluetooth* wireless technology to a PC to share the same schedules. When you exchange entries with other devices, the date and time displayed may be different to that of the original data depending on the data format of the receiving device.

Creating a New Entry

“Organiser” → “Calendar”

1. Select the desired day to which you wish to add an event.
2. Press [Options] and select “Add New Entry”.
3. Enter the subject.
4. Enter the location.
5. Select the desired category.
6. Enter the start date and then enter the start time.
7. Select the duration.

When selecting “Other”, enter the desired reminder date and time.

8. Select the reminder time.

When selecting “Other”, enter the desired reminder date and time.

9. Press [Save].

Note

- *If the date and time settings have not been entered, the date and time entry screen is displayed (p. 104).*
- *The reminder will not sound when “Ringer Volume” (p. 97) is set to “Silent”.*

To Change the Type of the Reminder Tone or Video

1. On the New Entry screen, select “Reminder”.
2. Select “Assign Tone/Video”.
3. Select “Assign Tone” and then select “Preset Sounds” or “Sound Gallery”, or select “Assign Video”.
4. Select the desired sound or video clip file.

For details on selecting a tone, see “Assigning a Ringtone” on page 98.

To Change the Duration of the Reminder Tone or Video

1. On the New Entry screen, select “Reminder”.
2. Select “Duration”.
3. Select the time period.

When you select “Other”, you can enter the desired time in two digits using the keypad.

To Change the Repeat Option of the Reminder

1. On the New Entry screen, select “Repeat”.
2. Select the desired repeat option.

To Enter the Description

1. On the New Entry screen, select “Description”.
2. Enter a memo for the schedule entry.

To Make the Entry Secret

1. On the New Entry screen, select “Secret”.
2. Select “On” to make the data secret or select “Off” to leave it as it is.

Viewing a Schedule Entry

“Organiser” → “Calendar”

1. Select the day you wish to view.

To Search By Date

1. In any view, press [Options] and select “Go to”.

2. Select “Today” to display today or “Enter Date” to enter the desired date.

Tip

- In the monthly or weekly view, you can control the view by using the following:

Monthly view

 : Displays the previous month.

 : Displays the next month.

 : Displays the weekly view.

 : Moves the cursor to today.

 : Moves the cursor to left (the previous day) or to right (the next day).

 : Moves the cursor upward (last week) or downward (next week).

Weekly view

 : Displays the previous week.

 : Displays the next week.

 : Displays the monthly view.

 : Moves the cursor to today.

 : Moves the cursor to left (the previous day) or to right (the next day).

 : Moves the weekly view up or down (the previous hour or next hour).

Editing a Schedule Entry

“Organiser” → “Calendar”

1. Select the day you wish to edit.
2. Highlight the entry you wish to edit, press [Options], then select “Edit”.
3. Select the desired item and modify the entry.
4. Press [Save].

Deleting Schedule Entries

1. In any view, press [Options] and select “Delete”.
2. Select the desired option.

“This Appointment” (daily view):

Deletes the selected entry.

“All This Day”: Deletes all entries for the selected day.

“All This Week” (weekly view):

Deletes all entries for the selected week.

“Up to Last Week” (weekly view):

Deletes all entries before this week.

“All This Month” (monthly view):

Deletes all entries for the selected month.

“Up to Last Month” (monthly view):

Deletes all entries before this month.

“All Appointments” (weekly and monthly view):

Deletes all entries in this application.

Sending a Schedule Entry

“Organiser” → “Calendar”

1. Select the day including schedule entries you wish to send.
2. Highlight the entry you wish to send, press [Options], then select “Send”.
3. Select “As Message” or “Via Bluetooth”.

For details, see “Bluetooth” on page 115.

Note

- *When pairing, you need to enter your passcode when establishing contact with a Bluetooth wireless technology enabled device for the first time.*

Receiving a Schedule Entry

When the phone receives a schedule entry, a confirmation message is displayed in standby.

1. Press [Yes].

The received entry is saved in the Calendar.
Press [No] to reject.

Tip

- For details on entering Bluetooth wireless settings, see “Connectivity” on page 115.

Viewing the Memory Status

1. In any view, press [Options] and select “Memory Status”.

Alarms (M 3–2)

Setting the Alarms

The alarm function allows you to be alerted at a specified time.

Note that you need to set the current date and time before setting the alarm function if it has not been done already.

Note

- The alarm will not ring when “Ringer Volume” (p. 97) is set to “Silent”.

“Organiser” → “Alarms”

1. Select the blank setting.
2. Enter the desired time.
3. Press [Save].

To Change the Type of Repeat Options

1. On the Set Alarm screen, select “Repeat”.
2. Select “Once Only”, “Every Day” or “Selected Days”.
“Once Only”: The alarm sounds once only.
“Every Day”: The alarm sounds every day at the specified time.
“Selected Days”: The alarm sounds on the selected day of the week at the specified time.





To Change the Type of Alarm Tone or Video Clip File

1. On the Set Alarm screen, select “Assign Tone/Video”.
2. Select “Assign Tone” and then select “Preset Sounds” or “Sound Gallery”, or select “Assign Video”.
3. Select the desired tone or video clip file.
For details on selecting a tone, see “Assigning a Ringtone” on page 98.

To Change the Snooze of the Alarm Tone

1. On the Set Alarm screen, select “Snooze”.
2. Select the desired snooze option.

To Change the Alarm Volume

1. On the Set Alarm screen, select “Alarm Volume”.
2. Press  (or ) to increase the volume or press  (or ) to decrease the volume.

To Change the Vibration of Alarm Tone

1. On the Set Alarm screen, select “Vibration”.
2. Select “On”, “Link to Sound” or “Off”.

For details on selecting a vibration, see “Vibration” on page 99.

To Change the Duration of the Alarm Tone

1. On the Set Alarm screen, select “Duration”.
2. Select the desired duration.

Resetting an Alarm Setting

“Organiser” → “Alarms”

1. Highlight the alarm you wish to reset.
2. Press [Options] and select “Reset Alarm”.

Resetting All Alarm Settings

“Organiser” → “Alarms” → “Clear All”

1. Press [Yes] or [No].

Calculator (M 3–3)

The calculator function performs the 4 arithmetic calculations using up to 12 digits.

“Organiser” → “Calculator”

The calculator is displayed on the display.

Key operations for calculation are as follows:

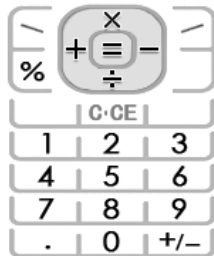

To enter a decimal point, press .

To clear the entered number or function, press .

To do the calculations, press .

To start a new calculation, press .

Rate Conversion

You can also use the calculator as a currency calculator to convert from/to a home currency using a conversion rate that you enter.

To Set a Currency Conversion Rate

“Organiser” → **“Calculator”** → [Options] → **“Currency Converter”** → **“Exchange Rate”**

1. Select “Domestic” or “Foreign”.
2. Enter the currency conversion rate.

To delete a digit, press .

To Convert a Value

“Organiser” → **“Calculator”**



1. Enter the value to be converted.
2. Press [Options] and select “Currency Converter”.
3. Select “Convert to Domestic” or “Convert to Foreign”.

Voice Recorder (M 3–4)

This allows you to record a voice clip, which can be used to remind you of schedule entries or be sent within a multimedia message. The recorded voice clip is saved in Sound Gallery. Voice clips are saved in .amr format.

Recording a Voice Clip

“Organiser” → **“Voice Recorder”**



1. Press  to start recording.
To stop recording before the recording time is over, press .
2. Select “Save” to save the voice clip.

Note

- Press  (or ) or  (or ) to adjust the sound volume when playing back the recorded file.

Sending Voice Clips

“Organiser” → **“Voice Recorder”**

1. Press  to start recording.
2. Press  to stop recording.
3. Select “Save and Send”.

For details on creating a message, see “Creating a New Message” on page 56.

Selecting the Record Time

“Organiser” → **“Voice Recorder”** → **[Options]** → **“Record Time”**

1. Select “For Message” or “Extended Voice”.

When selecting “Extended Voice”, you can save the voice clip only in a memory card automatically.

Selecting the Storage Memory

“Organiser” → **“Voice Recorder”** → **[Options]** → **“Save Recording To”**

1. Select the desired location.

When selecting “Choice”, you can select the location when saving a voice clip.

Stopwatch (M 3–5)

You can store 4 lap times when using the stopwatch function.

“Organiser” → **“Stopwatch”**

1. Press **○** to start.

Press [LAP] to view the lap time before the stopwatch stops. Last 4 lap times are saved.

2. Press **○** to stop.

Tip

- You can save a record of lap time and stop time in Text Templates by pressing [Options] and selecting “Save to Templates”.

Resetting Time

1. After stopping the stopwatch, press [Options] and select “Reset”.

Tasks (M 3–6)

You can register your schedule as task entries for a given date or time.

Creating a New Entry

“Organiser” → **“Tasks”**

1. Select “Add New Entry”.

2. Enter the subject.

3. Enter the due date and then due time.

4. Select the reminder time.

When selecting “Other”, enter the desired reminder date and time.

5. Press [Save].

Note

- If the date and time settings have not been entered, the date and time entry screen is displayed (p. 104).

To Change the Type of Alarm Tone or Video Clip File

1. On the Reminder screen, select “Assign Tone/Video”.
2. Select “Assign Tone” and then select “Preset Sounds” or “Sound Gallery”, or select “Assign Video”.
3. Select the desired tone or video clip file.

For details on selecting a tone, see “Assigning a Ringtone” on page 98.

To Change the Duration of Alarm Tone or Video

1. On the Reminder screen, select “Duration”.
2. Select the desired duration.

To Change the Description

1. On the New Entry screen, select “Description”.
2. Enter a memo for the task entry.

To Make the Entry Completed or Uncompleted

“Organiser” → **“Tasks”**

1. Highlight the desired entry.
2. Press .
3. On the view screen, press [Options] and select “Check”.

To make the entry uncompleted, select “Uncheck”.

To Make the Entry Secret

1. On the New Entry screen, select “Secret”.
2. Select “On” to make the data secret or select “Off” to leave it as it is.

Sending a Task Entry

“Organiser” → **“Tasks”**

1. Highlight the task entry you wish to send.
2. Press [Options] and select “Send”.
3. Select “As Message” or “Via Bluetooth”.

For details, see “Bluetooth” on page 115.

Note

- *When pairing, you need to enter your passcode when establishing contact with a Bluetooth wireless technology enabled device for the first time.*

Viewing the Memory Status

“Organiser” → *“Tasks”*

1. Press [Options] and select “Memory Status”.

Deleting Entries

“Organiser” → *“Tasks”* → [Options] → *“Delete”*

1. Select the desired option.

“This Task”:	Deletes the selected entry.
“All Completed Tasks”:	Deletes all checked entries.
“All Tasks”:	Deletes all entries.

World Clock (M 3–7)

Setting the Time Zone

“Organiser” → *“World Clock”*

1. Press [Edit].
2. Select “Set Time Zone”.
The current time zone is indicated on the world map.
3. Press ◀ or ▶ to change the time zone.
4. Press .

To Set the Custom Time Zone

“Organiser” → *“World Clock”*

1. Press [Edit].

2. Select “Set Time Zone”.

The current time zone is indicated on the world map.

3. Press [Options] and select “Set Custom Zone”.
4. Enter the desired city name and time.

Setting the Daylight Saving

“Organiser” → *“World Clock”*

1. Press [Edit].
2. Select “Daylight Saving”.
3. Select “On” or “Off”.

Countdown Timer (M 3–8)

“Organiser” → *“Countdown Timer”*

1. Enter the time to count.
You can set the time from 1 second to 60 minutes.
2. Press to start counting.
3. Press to pause.
Press again to continue counting.
4. If the countdown has finished, press [Cancel] and then press to start the countdown again.

Editing the Countdown Time

1. In the countdown start screen, press [Options] and select “Edit”.
2. Modify the desired time.

Expenses Memo (M 3–9)

You can record an expenses memo with predefined or edited categories.

Recording in the Expenses Memo

“Organiser” → **“Expenses Memo”** → **“Add New Expense”**

1. Enter the expenses using the digit keys.
2. Select the desired category.
Expenses memo is registered.

Viewing Totals

“Organiser” → **“Expenses Memo”** → **“Totals”**

Recorded expenses are displayed on the screen.

To Change Category

1. In the total view, select the desired item.
2. Press [Options] and select “Change Category”.
3. Enter a category name.

To Change Amount

1. In the total view, select the desired item.
2. Press [Options] and select “Change Amount”.
3. Enter the desired amount using the digit keys.

To Delete a Recorded Item

1. In the total view, select the desired item.
2. Press [Options] and select “Delete Item”.
The selected item is deleted from the list.

To Delete All Items

1. In the total view, select the desired item.
2. Press [Options] and select “Delete All”.

Editing the Category Name

“Organiser” → **“Expenses Memo”** → **“Edit Category”**

1. Select the desired category name.
2. Modify the name.

Phone Help (M 3–10)

You can view the help list and use it to guide you in the phone’s functions.

“Organiser” → **“Phone Help”**

1. Press ▲ or ▼.

SIM Application (M 10)

You can enjoy applications on the SIM/USIM card. Please contact your service provider for further details.

Settings (M 9)

Profiles (M 9–1)

The tone sound and vibration settings can be customised for each profile according to your environment.

There are 6 profiles: “Normal”, “Meeting”, “Activity”, “Car”, “Headset” and “Silent”.

Activating a Profile

“Settings” → “Profiles”

1. Select the desired profile.

Note

- When a profile is set, the corresponding indicator described on page 19 is displayed in standby.

Tip

- Long press  to switch Profiles settings between the mode most recently activated and Silent mode in standby.

Resetting Profile Settings

“Settings” → “Profiles”

1. Highlight the profile you wish to reset.
2. Press [Options] and select “Set to Default”.









3. Enter your handset code.

The default handset code is “9999”. For details on changing the handset code, see “To Change the Handset Code” on page 112.

Ringer Volume

You can adjust the ringer and general volume.

“Settings” → “Profiles”

1. Highlight the profile you wish to customise.
2. Press [Options] and select “Personalise”.
3. Select “Volume”.
Each current volume level is displayed.
4. Select “For Incoming Call”, “For New Message” or “General Volume”.
5. Press  (or ) to increase the ringer volume or press  (or ) to decrease the ringer volume and then press .
To select “Increasing Volume”, press  (or ) at level 5.
To select “Silent”, press  (or ) at level 1.

Tip

- You can select from two levels or an increasing volume, when selecting the “Silent” profile.

Note

- *“Increasing Volume” may not be assigned for “General Volume”.*

Assigning a Ringtone

You can select the ringtone from 28 tones including 5 patterns, 13 sound effects and 10 melodies. You can also select a sound in Sound Gallery as the default ringtone excluding the AMR or WAVE format.

“Settings” → “Profiles”

1. Highlight the profile you wish to customise.
2. Press [Options] and select “Personalise”.
3. Select “Ringtone/Ringvideos”.
4. Select “For Voice Call” or “For Video Calling”.
5. Select “Assign Tone”.
6. Select “Preset Sounds” or “Sound Gallery”.
7. Highlight the ringtone you wish to use.
To hear the demo play, press [Options] and select “Play”.
8. Press [Options] and select “Assign”.

Note

- *Even if you delete a ringtone that uses a sound in Sound Gallery, the setting remains the same and the default ringtone sounds. If you delete a ringtone assigned for the ringtone, the default ringtone is set.*

Assigning a Ring Video Clip File

You can select a video clip file in Video Gallery as the default ring video clip file.

“Settings” → “Profiles”

1. Highlight the profile you wish to customise.
2. Press [Options] and select “Personalise”.
3. Select “Ringtone/Ringvideos”.
4. Select “For Voice Call” or “For Video Calling”.
5. Select “Assign Video”.
6. Highlight the ring video clip file you wish to use.
To preview the file, press [Options] and select “Play”.
7. Press [Options] and select “Select”.

Message Notification

When receiving messages, your phone will notify you of their arrival with the ringtone or ring video you specify.

“Settings” → “Profiles”

1. Highlight the profile you wish to customise.
2. Press [Options] and select “Personalise”.
3. Select “Ringtone/Ringvideos”.
4. Select “For New Message”.
5. Select “Assign Tone” or “Assign Video”.
If “Assign Tone” is selected, select “Preset Sounds” or “Sound Gallery”.
6. Highlight the desired ringtone or ring video clip file.
For details on selecting a ringtone or a ring video, see “Assigning a Ringtone” or “Assigning a Ring Video Clip File” on page 98.
7. Press [Options] and select “Assign” (for a ringtone) or “Select” (for a video clip).
8. Select “For New Message” and select “Duration”.
9. Enter the desired duration.

Keypad Tones

When the keypad tone is set on, you will hear a confirmation tone each time you press any keys.

“Settings” → “Profiles”

1. Highlight the profile you wish to customise.
2. Press [Options] and select “Personalise”.
3. Select “System Sounds”.
4. Select “Keypad Tones”.
5. Highlight the desired tone pattern.
6. Press [Options] and select “Assign”.

Vibration

“Settings” → “Profiles”

1. Highlight the profile you wish to customise.
2. Press [Options] and select “Personalise”.
3. Select “Vibration”.
4. Select “On”, “Link to Sound” or “Off”.

Tip

- When the “Link to Sound” option is selected in step 4, the vibrator synchronises with your selected melody to pulse in time with the melody. Please note that not all melodies support the “Link to Sound” option.
- When you select “On” or “Link to Sound” in step 4, “” is displayed in standby.

Event Light

When the light option is on, the small light blinks while the phone receives a call or message.

“Settings” → “Profiles”

1. Highlight the profile you wish to customise.
2. Press [Options] and select “Personalise”.
3. Select “Event Light”.
4. Select “For Voice Call”, “For Video Calling” or “For New Message”.
5. Select “On”, “Link to Sound” or “Off”.

Tip

- When the “Link to Sound” option is selected in step 5, the small light pulses in time with the selected melody. Please note that not all melodies support the “Link to Sound” option.



Status Light

When the light option is on, the small light blinks to let you know when you have missed calls or new messages.

“Settings” → “Profiles”

1. Highlight the profile you wish to customise.
2. Press [Options] and select “Personalise”.
3. Select “Status Light”.
4. Select “For Missed Call” or “For New Message”.
5. Select “On” or “Off”.

Any Key Answer

You can answer a call by pressing any key except ,  and [Busy]. For details, see page 23.

“Settings” → “Profiles”

1. Highlight the profile you wish to customise.
2. Press [Options] and select “Personalise”.
3. Select “Any Key Answer”.
4. Select “On” or “Off”.

Setting the Display (M 9–2)

You can change the settings of the main and sub displays.

Setting the Main Display

Wallpaper

For the standby screen, 3 default pictures are provided. Pictures taken with the digital camera or images downloaded from a WAP site can be used for wallpapers.

Setting from Picture Gallery

“Settings” → **“Display Settings”** → **“Wallpaper”**

1. Select “Picture Gallery”.
2. Select the desired picture.
3. After displaying the picture, press .

Note

- Some pictures cannot be used because of their picture and data types.
- If the picture in Picture Gallery is already set, it is displayed in step 1. Press [Change] and select the desired picture.

Assigning the Pictures

Pictures can be displayed when turning the power on or off, when receiving an incoming call, or when operating the alarm. Pictures taken with the digital camera or images downloaded from a WAP site can be used.

To Set Built-in Pictures

“Settings” → **“Display Settings”** → **“Assign Pictures”**

1. Select the desired scene to set the picture to.
Select “Pattern 1”, “Pattern 2” or “Pattern 3” when you select “Incoming” or “Alarm”.

To Set Saved Pictures

“Settings” → **“Display Settings”** → **“Assign Pictures”**

1. Select the desired scene to set the picture to.
2. Select “Picture Gallery”.
3. Select the desired picture.
4. After displaying the picture, press .
5. Specify the area you wish to display using the navigation keys.

Note

- Some pictures cannot be used because of their picture and data types.
- If the picture in Picture Gallery is already set, it is displayed in step 2. Press [Change] and select the desired picture.

Setting the Greeting Message

You can set the message which is displayed when the phone is turned on.

“Settings” → **“Display Settings”** → **“Greeting Message”** → **“Switch On/Off”**

1. Select “On” or “Off”.
2. Select “Edit Message” and enter the message when you select “On” in step 1.

Up to 10 characters can be saved as a message.

Backlight

The backlight will shut off if you do not press the keypad for a certain length of time. You can specify a desired time to elapse before the backlight shuts off, which will help conserve battery life.

Tip

- *When you purchase this phone, Backlight is set to 15 seconds.*

To Select the Backlight Time Out



“Settings” → **“Display Settings”** → **“Backlight”** → **“Time Out”**

1. Select the desired time.
Select “Off” to shut it off.

Adjusting the Brightness of the Backlight

You can adjust the brightness of the backlight of the screen between 4 levels.

“Settings” → **“Display Settings”** → **“Backlight”** → **“Brightness”**

1. Press  (Bright) and  (Dark) for maximum clarity.
2. Press .

Setting the Display Saving

The screen of this phone will automatically turn off after a given amount of time. You can change the length of time before the Display Saving goes into effect, which will help conserve battery life.

Tip

- When you purchase this phone, Display Saving is set to 2 minutes.

“Settings” → **“Display Settings”** → **“Display Saving”**

1. Select the desired time.

Note

- Display Saving does not work while you are making a call, using WAP, or using an application.
- To cancel the Display Saving: The display saving continues until either a key is pressed or there is an incoming alert. The first key press only cancels this function. You must press another key in order to enter any numerical or text value.

Setting the External Display

To Turn On/Off the External Display

You can turn the external display on or off when the phone is closed.

“Settings” → **“Display Settings”** → **“Sub Display”** → **“Switch On/Off”**

1. Select “On” to turn external display on or “Off” to turn external display off.

To Select the Backlight Time Out

“Settings” → **“Display Settings”** → **“Sub Display”** → **“Backlight”**

1. Select the desired time out.
Select “Off” to shut the backlight off.

To Adjust the LCD Contrast

You can adjust the LCD contrast to suit certain lighting conditions.

“Settings” → **“Display Settings”** → **“Sub Display”** → **“LCD Contrast”**

1. Press  (Bright) or  (Dark) to adjust the contrast and press .

The LCD contrast can be adjusted to 9 levels.

To Set Incoming Indication

Caller number or registered caller name can be displayed on the external display when receiving an incoming call.

“Settings” → **“Display Settings”** → **“Sub Display”** → **“Caller Display”**

1. Select “On” or “Off”.

Sound Settings (M 9–3)

You can use this menu to check or edit the current Profiles settings (except “Any Key Answer”).



Date & Time (M 9–4)

You need to set the correct time and date in order for your phone’s various time-based functions to work correctly.

“Settings” → **“Date & Time”** → **“Set Date/Time”**

1. Enter the day, month and year using the digit keys.
2. Enter the time using the digit keys.

Tip

- When you enter the time in the 12-hour format, press  or  to switch between am and pm. The order in which the date and time is displayed is based on the format setting.



Setting the Daylight Saving

“Settings” → **“Date & Time”** → **“Daylight Saving”**

1. Select “On” or “Off”.



Setting the Time Zone

“Settings” → **“Date & Time”** → **“Set Time Zone”**

1. Press  or  to select the home city to set.
2. Press .

Customising the Time Zone

“Settings” → **“Date & Time”** → **“Set Time Zone”** → **[Options]** → **“Set Custom Zone”**

1. Enter the city name.
2. Enter the time–zone differences using the digit keys.
Press  or  to switch between – and +.
3. Press .

Display Date & Time

You can display the calendar or the current date and/or time in standby.

To Set the Clock Display

“Settings” → **“Date & Time”** → **“Display Date & Time”**
→ **“Show Clock”**

1. Select the desired clock type or “Off” to set clock display off.

To Set the Calendar Display

“Settings” → **“Date & Time”** → **“Display Date & Time”**
→ **“Show Calendar”**

1. Select the desired calendar type or “Off” to set calendar display off.

World Clock

For details, see page 94.

Selecting the Time Format

“Settings” → **“Date & Time”** → **“Time Format”**

1. Select “24 Hour” or “12 Hour”.

Selecting the Date Format

“Settings” → **“Date & Time”** → **“Date Format”**

1. Select “D–M–Y”, “M–D–Y” or “Y–M–D”.

Setting the Calendar Format

“Settings” → **“Date & Time”** → **“Calendar Format”**

1. Select “Sunday–Saturday” or “Monday–Sunday”.

Language Setting (M 9–5)

You can change the language that the phone uses to display messages.

“Settings” → **“Language”**

1. Select the desired language.

Note

- If you select “Automatic” in step 1, the language preset on the SIM/USIM card is selected.
- If the language preset on the SIM/USIM card is not supported, then the default language of the phone is selected.

Tip

- You can also change the input language on the text entry screen (p. 33).

Call Settings (M 9–6)

Set various types of functions and services for voice calls.

Voicemail & Diverts

This service can be used to divert incoming calls that you cannot answer. Calls can be diverted to another phone number or to your Voice mail system.

Note

- *This service may not be available on all mobile phone networks. Contact your service provider for more information.*

To Set the Voice Mail Numbers

You can divert calls to the network Voice mail service centre. Depending on whether you are inside or outside your network area, you can set two Voice mail numbers, a number for your home network area or for a roaming network area.

Note

- *This service depends on the SIM/USIM card. Contact your SIM/USIM card vendor for more information.*

“Settings” → “Call Settings” → “Voicemail & Diverts” → “Voicemail” → “Settings” → “Voicemail Centre Number”

1. Enter the desired phone number.

To Access the Voice Mail Centre

1. Long press  in standby.

To Activate the Voice Mail Service

“Settings” → “Call Settings” → “Voicemail & Diverts” → “Voicemail” → “Activate”

1. Select one of the following options:

“Always”:	Diverts all calls without ringing.
“When Busy”:	Diverts incoming calls while you are talking on the phone.
“No Answer”:	Diverts incoming calls if you do not answer a call within a certain period of time.
“Not Reachable”:	Diverts incoming calls when your phone has no network service or is switched off.

If you select “No Answer”, select the period of time from 6 levels (05 to 30 seconds).

2. Press .

To Activate the Diverts Service

Select the appropriate option.

“Settings” → **“Call Settings”** → **“Voicemail & Diverts”**
→ **“Diverts”**

1. Select “Activate” or “By Service”.

If you select “By Service”, you can select further divert options.

2. Select “Always”, “When Busy”, “No Answer” or “Not Reachable”.

If you select “No Answer”, select the period of time from 6 levels (05 to 30 seconds).

3. Enter a phone number to which you wish to divert calls or search for it in the Phonebook (p. 44).
4. Press .

Note

- When “Voice Calls” diverts are set to “Always”, “” is displayed in standby.

To Check the Diverts Status

“Settings” → **“Call Settings”** → **“Voicemail & Diverts”**
→ **“Status”**

1. Select the diverts option you wish to check.

To Deactivate the Diverts/Voice Mail Service

“Settings” → **“Call Settings”** → **“Voicemail & Diverts”**
→ **“Deactivate”**

1. Select the desired option.

To Cancel the Diverts and Voice Mail Service

Once you have changed the diverts settings, you can cancel them all with this service.

“Settings” → **“Call Settings”** → **“Voicemail & Diverts”**
→ **“Cancel All”**

Call Waiting

Note

- This service may not be available on all mobile phone networks. Contact your network operator for more information.

If you wish to be able to receive another incoming call while you have a call in progress, you must activate the Call Waiting service.

“Settings” → **“Call Settings”** → **“Call Waiting”**

1. Select “On”, “Off” or “Status”.

Restrict Calls

This function lets you place restrictions on incoming and outgoing calls. To activate this option you will need the specified password, which is available from your service provider.

“Settings” → “Call Settings” → “Restrict Calls”

1. Select from one of the following options:

- “Outgoing Calls”: Restricts outgoing calls.
- “Fixed Dialling Number”: Restricts calls for fixed dialling numbers in the Phonebook.
- “Incoming Calls”: Restricts incoming calls.
- “Rejected Numbers”: You can register for dialling numbers to be restricted.
- “Withheld Call”: Restricts withheld calls.
- “Change N/W Password”: Changes the network password.

2. Select one of the following options:

(For “Outgoing Calls”)

- “Bar All Outgoing Calls”: Restricts all outgoing calls except emergency calls.
- “Bar International Calls”: Restricts all outgoing international calls.
- “Only Local & Home”: Restricts all outgoing international calls except to your home country.

(For “Incoming Calls”)

- “Bar All Incoming Calls”: Restricts all incoming calls.
- “Bar if Abroad”: Restricts all incoming calls when you are outside of the coverage from your registered network operator.

3. Select one of the following options:

(For “Outgoing Calls” and “Incoming Calls”)

- “All Services”: Restricts all services.
- “Voice Calls”: Restricts all voice calls.
- “Video Callings”: Restricts all video callings.
- “Fax”: Restricts all fax calls.
- “Messages”: Restricts all messages.

4. Select “On”, “Off” or “Status”.

5. Enter the network password.

To Cancel Settings

“Settings” → “Call Settings” → “Restrict Calls”

1. Select “Outgoing Calls” or “Incoming Calls”.
2. Select “Cancel All”.
3. Enter the network password.

Fixed Dialling Number

When the Fixed Dialling Number is enabled, you can only call pre-registered numbers.

To Enable Fixed Dialling Number

“Settings” → **“Call Settings”** → **“Restrict Calls”** → **“Fixed Dialling Number”** → **“Switch On/Off”**

1. Select “On” to enable this function.

To Add a New Name

“Settings” → **“Call Settings”** → **“Restrict Calls”** → **“Fixed Dialling Number”** → **“Edit Dial List”**

1. Highlight the blank entry, press [Options], then select “Add New Dial”.
2. Enter your PIN2 code.
3. Add a name and a phone number.

For details on adding a name and a phone number, see “Add New” on page 43.

4. Press [Save].

Rejecting an Incoming Call

You can register phone numbers you do not wish to answer.

To Reject the Registered Number

“Settings” → **“Call Settings”** → **“Restrict Calls”** → **“Rejected Numbers”** → **“Switch On/Off”**

1. Select “On” or “Off”.

To Register the Rejected Number

“Settings” → **“Call Settings”** → **“Restrict Calls”** → **“Rejected Numbers”** → **“Set Rejecting Number”**

1. Select a blank field.
2. Enter the desired number.

Changing the Network Password

“Settings” → **“Call Settings”** → **“Restrict Calls”** → **“Change N/W Password”**

1. Enter the old network password.
2. Enter a new network password.
3. Enter the new network password again.

If you enter the incorrect password, you are asked to enter the password again.

4. Press .

Minute Minder

Minute Minder function informs you of your talk time by sounding a tone after every minute.

“Settings” → “Call Settings” → “Minute Minder”

1. Select “On” or “Off”.

Displaying Call Timer

“Settings” → “Call Settings” → “Display Call Timer”

1. Select “On” or “Off”.

Displaying Call Costs

“Settings” → “Call Settings” → “Display Call Cost”

1. Select “On” or “Off”.

Auto Redial

“Settings” → “Call Settings” → “Auto Redial”

1. Select “On” or “Off”.

Video Calling Settings (M 9–7)

Set various types of functions and services for video callings.

Selecting the Camera Picture

You can select an image shown to the caller between the sub camera image and an alternative image.

“Settings” → “Video Calling Settings” → “Camera Picture”

1. Select “Default Image” or “Alternative Image”.

For “Default Image”, select “Internal Camera” or “Alternative Image”.

For “Alternative Image”, select “Preset Picture” or “Picture Gallery”.

Turning On or Off the Speaker

“Settings” → “Video Calling Settings” → “Loudspeaker”

1. Select “On” to turn on the loudspeaker on the back of the phone, or select “Off” to turn it off.

Selecting the Picture Quality

Select the desired data format for your environment.

“Settings” → “Video Calling Settings” → “Incoming Picture Quality”

“Settings” → “Video Calling Settings” → “Outgoing Picture Quality”

1. Select “Normal”, “Quality Priority” or “Frame Rate Priority”.

Select “Frame Rate Priority” to perform faster communication.

Backlight

With this setting On, the phone's backlight is on when making a video calling.

“Settings” → “Video Calling Settings” → “Backlight”

1. Select “Always On”, “Always Off” or “As Normal Setting”.

The “As Normal Setting” option depends on the backlight setting of the main display (p. 102).

Mute

You can mute the microphone while making a video calling.

“Settings” → “Video Calling Settings” → “Mute Microphone”

1. Select “Off” to cancel the mute.

Assigning Hold Guidance Picture

You can display an image saved in the phone on your main display while you are putting a call on hold.

“Settings” → “Video Calling Settings” → “Hold Guidance Picture”

1. Select “Preset Picture” or “Picture Gallery”.
2. Select the desired picture.

Security (M 9–8)

Enabling/Disabling the PIN Code

If the PIN code is enabled you are asked to enter the PIN code each time the phone is switched on. Your PIN code is registered on the SIM/USIM card and you should have been made aware of the code when you purchased the SIM/USIM card. Contact your service provider for further details.

“Settings” → “Security Settings” → “PIN Entry” → “Switch On/Off”

1. Select “On” to enable the PIN code or “Off” to disable.
2. Enter your PIN code.

Note

- If you enter the wrong PIN code three times in step 2, the SIM/USIM card will lock. To remove the lock, contact your service provider or SIM/USIM card vendor.

To Change the PIN Code

This allows you to change the PIN code registered on the SIM/USIM card. Before you change the PIN code, select “On” in step 1 in “Enabling/Disabling the PIN Code” on page 111.

“Settings” → “Security Settings” → “PIN Entry” → “Change PIN”

1. Enter the existing PIN code.
2. Enter a new PIN code.
3. Enter the new PIN code again.

Changing the PIN2 Code

The PIN2 code is used to protect certain functions in the phone such as Fixed Dialling Number and call cost limits. The following shows you how to change the PIN2 code.

“Settings” → “Security Settings” → “Change PIN2”

1. Enter the existing PIN2 code.
2. Enter a new PIN2 code.
3. Enter the new PIN2 code again.

Handset Lock

The Handset Lock is an additional security feature which prevents unauthorised use of the phone or certain features.

“Settings” → “Security Settings” → “Handset Lock”

1. Select “On” or “Off”.

2. Enter your handset code.

The default handset code is “9999”. For details on changing the handset code, see “To Change the Handset Code”.

To Change the Handset Code

Before you change the handset code, select “On” in step 1 in “Handset Lock”.

“Settings” → “Security Settings” → “Change Handset Code”

1. Enter the old handset code.
2. Enter a new handset code.
3. Enter the new handset code again.

Function Lock

By setting this option on, all the functions of your phone will be locked until the correct handset code is entered.

“Settings” → “Security Settings” → “Function Lock”

1. Enter your handset code.

The default handset code is “9999”. For details on changing the handset code, see “To Change the Handset Code”.

To Turn Off the Function Lock

Enter your handset code in standby to turn the Function Lock off.

Showing Secret Data

By setting this option on, the hidden data can be displayed.

“Settings” → “Security Settings” → “Show Secret Data”

1. Select “On” to display or “Off” to hide.

Card Settings (M 9–9)

Formatting Memory Card

“Settings” → “Card Settings” → “Format Card”

1. Enter your handset code.
The default handset code is “9999”. For details on changing the handset code, see “To Change the Handset Code” on page 112.
2. Press [Yes] to start formatting.

Master Reset (M 9–10)

You can reset some of the settings or all the settings from M1 to M12.

Resetting Some of the Settings

“Settings” → “Master Reset” → “Reset Settings”

1. Enter your handset code.
The default handset code is “9999”. For details on changing the handset code, see “To Change the Handset Code” on page 112.

Resetting All Settings from M1 to M12

“Settings” → “Master Reset” → “Reset All”

1. Enter your handset code.
The default handset code is “9999”. For details on changing the handset code, see “To Change the Handset Code” on page 112.

Call Log (M 11)



The phone will record the last 30 missed calls, received calls and dialled numbers.

Viewing Call Log

“Call Log”

1. Select “All Calls”, “Dialled Numbers”, “Missed Calls” or “Received Calls”.

The selected call log list is displayed.

To switch logs, press  or .

2. Select the phone number you wish to view.

If you wish to dial the number, press .

Tip

- You can also confirm call logs by pressing  in standby.

Sending Messages

1. In the call log list, highlight the call log you wish to send a message to.
2. Press [Options] and select “Create Message”.

For details on creating a message, see “Creating a New Message” on page 56.

Deleting a Call Log

1. In the call log list, press [Options] and select “Delete”.

Call Timers (M 11–5)

This function lets you check the duration of your calls.

Checking the Duration of the Last Call and All Calls

“Call Log” → “Call Timers”

1. Select “Received Calls” or “Dialled Calls”.

The duration of the last call and all calls is displayed.

Resetting Call Timers

“Call Log” → “Call Timers” → “Clear Timers”

1. Enter your handset code.

The default handset code is “9999”. For details on changing the handset code, see “To Change the Handset Code” on page 112.

Data Counter (M 11–6)

You can confirm the number of bytes used in the 3G (UMTS) transmission.

“Call Log” → “Data Counter”

1. Select “Last Data” or “All Data”.

Resetting All Data Counter

“Call Log” → “Data Counter” → “Clear Counter”

Connectivity (M 12)

By configuring the settings in this menu, you can connect to *Bluetooth* wireless technology enabled phones or a PC via *Bluetooth* wireless technology.

Bluetooth (M 12–1)

For using the *Bluetooth* wireless function, you need to search for other *Bluetooth* wireless technology enabled devices to establish contact with your phone. Keep your phone within a distance of 10 metres from the devices before searching.

Using the Bluetooth Wireless Function

To Turn On or Off

“Connectivity” → “Bluetooth” → “Switch On/Off”

1. Select “On” or “Off”.

The *Bluetooth* wireless setting is activated, and “” is displayed.

To Show or Hide Your Phone

“Connectivity” → “Bluetooth” → “Visibility”

1. Select the desired visibility settings.

“Show My Phone”: Allows other devices to recognise your phone.

“Hide My Phone”: Hides your phone from other devices.

To Search for Devices to be Paired

“Connectivity” → “Bluetooth” → “Search for Devices”

The phone starts searching for devices within 10 metres. A maximum of 16 devices can be searched for and listed on the display.

1. Select the desired device for pairing.
2. Enter the device passcode.

Note

- If the *Bluetooth* wireless function is off before searching, the phone turns the *Bluetooth* wireless function on automatically and starts searching.
- You can only select one device for pairing. To change the paired device, see “To Activate the Paired Device” on page 116.

Tip

- You can save battery power by turning the *Bluetooth* wireless function off while it is not in use. Turn the *Bluetooth* wireless function off in “To Turn On or Off” on this page or in “To Turn Off Automatically” on page 117.
- During a call, you can divert voice calls to the paired handsfree device. Press [Options], select “Transfer Audio” and then “To Bluetooth” or “To Handset”.

To Activate the Paired Device

Paired devices are listed by tabs for all devices and for handsfree devices.

“Connectivity” → “Bluetooth” → “Paired Devices”

1. Press  to switch to the list for handsfree devices.
2. Select the desired device you wish to activate.



To Check and Uncheck the Paired Handsfree Devices

“Connectivity” → “Bluetooth” → “Paired Devices”

1. Select handsfree device list.
2. Press [Options] and select “Check” or “Uncheck”.

To Rename or Delete the Paired Devices

“Connectivity” → “Bluetooth” → “Paired Devices”

1. Press  or  to switch between all devices and handsfree devices.
2. Highlight the desired device.
3. Press [Options].
4. Select “Change Name” or “Delete”.
You can rename or delete by pressing after selecting desired device.

To Send All Data to Other Devices

You can send all the data for applications such as Phonebook, Calendar, Tasks, etc. to selected devices.

“Connectivity” → “Bluetooth” → “Send All”

1. Select the desired device.

If a device is not specified, searching starts automatically.

2. Enter your handset code.

The default handset code is “9999”. For details on changing the handset code, see “To Change the Handset Code” on page 112.

3. Enter the device passcode for unpaired devices.

4. Select the desired data to send.

Note

- *If the handsfree device is connected, the confirmation screen to deactivate the handsfree function is displayed. Press [Yes] to deactivate.*

Bluetooth Wireless Settings

With this setting you can rename your phone, prevent other phones from recognising your phone, turn the *Bluetooth* wireless function off automatically to save battery power, etc.

To Rename Your Phone

You can rename your phone. The name is shown in other devices when your phone is detected.

“Connectivity” → “Bluetooth” → “Bluetooth Settings” → “Device Name”

1. Enter the new device name.

To Turn Off Automatically

“Connectivity” → **“Bluetooth”** → **“Bluetooth Settings”**
→ **“Bluetooth Timeout”**

1. Select the desired time.

Your phone turns the function off automatically in the specified time.

To Switch the Handsfree Settings

You can switch modes of the handsfree kit between two modes; talking with the handsfree kit or talking with the phone.

“Connectivity” → **“Bluetooth”** → **“Bluetooth Settings”**
→ **“Handsfree Setting”**

1. Select “Private mode” or “Handsfree mode”.

“Private mode”: For talking with the handset

“Handsfree mode”: For talking with the handsfree kit

To Turn the Authentication Request On or Off

You can request the sender or receiver of the OBEX data to authenticate the passcode (exchanging the passcode) before pairing devices.

“Connectivity” → **“Bluetooth”** → **“Bluetooth Settings”**
→ **“Authentication”**

1. Select “On” or “Off”.

Note

- No authentication is required for the paired devices.
- Even if you select “Off”, you may authenticate the passcode when the sender requests it.

To See Your Phone Details

“Connectivity” → **“Bluetooth”** → **“Bluetooth Settings”**
→ **“My Phone Details”**

Network Settings (M 12–2)

Selecting a Service Automatically

Each time the power is turned on, your phone selects a service automatically.

“Connectivity” → **“Network Settings”** → **“Select Service”**

1. Select “Auto”.

Selecting a Service Manually

“Connectivity” → **“Network Settings”** → **“Select Service”**

1. Select “GSM”.

Selecting a Network Automatically

Each time the power is turned on, your phone always tries to connect to the preferred network.

If your phone is not connected to the network, you can perform the following immediately to establish the preferred network connection.

“Connectivity” → **“Network Settings”** → **“Select Network”** → **“Automatic”**

Setting the Network Manually

“Connectivity” → **“Network Settings”** → **“Select Network”** → **“Manual”**

1. Select the desired network.

Adding a New Network

“Connectivity” → **“Network Settings”** → **“Select Network”** → **“Add New Network”**

If there are no entries, press and go to step 2.

If there is an entry, press and perform the following steps.

1. Select “Add”.
2. Enter the country code (up to 3 digits).
3. Enter the network code (up to 3 digits).
4. Enter a new network name (up to 25 characters).
5. Select “Select network type”.
6. Select the desired network.

Editing the Preferred List

“Connectivity” → **“Network Settings”** → **“Select Network”** → **“Set Preferred”**

1. Select the name of the network you wish to edit.
2. Select “Insert” to insert over the selected position, “Add to end” to insert at the end or “Delete” to delete.

Showing the Network Information

“Connectivity” → **“Network Settings”** → **“Network Information”**

Information about the operator name, package and services are displayed.

Internet Settings (M 12–3)

Note

- *In normal operations, you do not need to change the settings.*
- *Internet settings have already been entered in your phone depending on your network operator. You may have restrictions on viewing, deleting, copying or modifying the settings. Contact your network operator for details.*

WAP Settings

“Connectivity” → **“Internet Settings”** → **“WAP Settings”** → **“Create New”**

“Profile Name”:	WAP profile name (Unique name)
“Proxy”:	Proxy setting for WAP
“Access Point”:	Access point for WAP (When “Use Proxy” is Off)
“Use Proxy”:	Setting to connect by Proxy or not

“Home”:	Home page URL (When “Use Proxy” is Off)
---------	---

Streaming Settings

“Connectivity” → **“Internet Settings”** → **“Streaming Settings”** → **“Create New”**

“Profile Name”:	Profile name for streaming (Unique name)
“Proxy Address”:	Proxy address
“Proxy Port Number”:	Port number (1-65535)
“Access Point”:	Access point

Proxy Settings

“Connectivity” → **“Internet Settings”** → **“Proxy Settings”** → **“Create New”**

“Proxy Name”:	Proxy name (Unique name)
“Proxy Address”:	IP address
“Access Point”:	Access point
“Home”:	Home page URL
“Port Number”:	Port number (1-65535)
“Authentication Type”:	Authentication Type (“HTTP-BASIC” or “HTTP-DIGEST”)
“User Name”:	User name for authentication
“Password”:	Password for authentication

APN Settings

“Connectivity” → “Internet Settings” → “APN Settings” → “Create New”

“Access Point Name”:	Access point name (Unique name)
“APN”:	APN setting
“Authentication Type”:	Authentication type (“NONE”, “PAP” or “CHAP”)
“User Name”:	User name for access point
“Password”:	Password for access point
“DNS”:	DNS (Domain Name System)
“Linger Time”:	Linger Time (1-99999 sec.)

Re-provisioning Settings

“Connectivity” → “Internet Settings” → “Re-provisioning Settings” → “Execute Pending”

Clearing DNS Cache

“Connectivity” → “Internet Settings” → “Clear DNS Cache”

To Activate the WAP/Streaming Profile

“Connectivity” → “Internet Settings”

1. Select “WAP Settings” or “Streaming Settings”.
2. Select the desired profile you wish to activate.

To Edit/Copy/Delete the WAP/Streaming Profile

“Connectivity” → “Internet Settings”

1. Select “WAP Settings” or “Streaming Settings”.
2. Highlight the desired profile.
3. Press [Options] and select the desired option.

“Edit”:

Modify the desired item

“Copy”:

Enter the new file name

“Delete”:

Press [Yes] to delete

Off Line Mode (M 12–4)

When the Off Line Mode is set to “On”, the phone cuts off the network connections and stops searching for available networks to connect. With this mode, you can play games or music even when you fly.

“Connectivity” → “Off Line Mode”

1. Select “On” or “Off”.

Backup/Restore (M 12–5)

With a memory card inserted in your phone, you can make backup files of Bookmarks, Text, Phonebook, Calendar and Tasks in the handset memory to the memory card. You can also restore the backup data from the memory card.

Making a Backup File on the Memory Card

“Connectivity” → “Backup/Restore” → “Backup”

1. Enter your handset code.

The default handset code is “9999”. For details on changing the handset code, see “To Change the Handset Code” on page 112.

2. Press [OK].
3. Select the desired item to backup.

To Backup All Files

“Connectivity” → “Backup/Restore” → “Backup”

1. Enter your handset code.
2. Press [OK].
3. Select “Select All”.

Restoring a Backup File

“Connectivity” → “Backup/Restore” → “Restore”

1. Enter your handset code.
2. Press [OK].

3. Select the desired item.

4. Select the desired file to restore.

A confirmation message indicating deletion from the handset memory is displayed on the screen.

5. Press [Yes].

To Restore All Files

“Connectivity” → “Backup/Restore” → “Restore”

1. Enter your handset code.

2. Press [OK].

3. Select “Select All”.

A confirmation message indicating deletion from the handset memory is displayed on the screen.

4. Press [Yes].

To Delete a Backup File

“Connectivity” → “Backup/Restore” → “Restore”

1. Enter your handset code.

2. Press [OK].

3. Select the desired item.

4. Highlight the desired file.

5. Press [Options] and select “Delete”.

A confirmation message to delete the selected file is displayed on the screen.

6. Press [Yes].

Connecting SX633A to Your PC

You can use the following functions by connecting the SX633A to your PC using a USB port* or *Bluetooth* wireless technology port:

- 3G/GSM GPRS modem
- Handset Manager for SX633A

* Requires an optional USB data cable XN-1DC30 for USB port connection.

System Requirements

Operating System:

Windows[®] 2000*, Windows[®] XP**

- * Service Pack 4 or later
- ** Service Pack 2 or later

Supported Software:

Microsoft[®] Outlook/Outlook Express

Interface:

USB port or *Bluetooth* wireless port

CD-ROM drive

3G/GSM GPRS Modem

You can use SX633A as a 3G/GSM GPRS modem to access the Internet from your PC. Connect your phone to your PC via *Bluetooth* wireless technology or USB interface. Software installation on your PC is required. For details, see “Software Installation” on page 123.

Modem via the USB Cable

To use the modem function using a USB cable, use the cable mentioned above and see the instructions accompanying the cable.

Modem via Bluetooth connection

To use the modem function via *Bluetooth* wireless technology interface, see “Using the Bluetooth Wireless Function” on page 115 and turn the modem function on.

For details on software support, refer to the following site:

<http://www.sharp-mobile.com>

Note

- *Modem communication is not possible while communicating with the Handset Manager via Bluetooth wireless technology or USB interface.*
- *Your phone exhausts the battery when connected to a PC, even when not communicating.*

Handset Manager

You can transmit the following items between your phone and your PC, and can use Phonebook entries on your PC:

- Gallery files (pictures/sounds/video clips/Other Documents data)
- Phonebook entries
- Schedule entries

For details on software support, refer to the following site:

<http://www.sharp-mobile.com>

Software Installation

1. Insert the CD-ROM (purchase separately) into your CD-ROM drive.

The SX633A CD-ROM screen is displayed.

If the SX633A CD-ROM screen is not displayed, double-click [Launcher.exe] in your CD-ROM.

2. Press the desired button.

The installation starts.

3. Follow the on-screen instructions to complete installation.

Note

- *The phone may not recognise the USB data cable if it is connected while an application (Camera, Gallery, etc.) is running. Connect the USB data cable in standby.*

3G/GSM GPRS modem

- *It is not recommended that you make or answer calls when you are using SX633A as a 3G/GSM GPRS modem. The operation may be interrupted.*

Handset Manager

- *Some large files may not be able to be transmitted from the PC to the phone.*
- *Applications (Camera, Gallery, etc.) do not run when the phone is connected to the PC via Bluetooth wireless technology interface or USB data cable.*

Troubleshooting

Problem	Solution
The phone does not turn on.	<ul style="list-style-type: none"> • Make sure the battery is properly inserted and charged.
PIN code or PIN2 code is rejected.	<ul style="list-style-type: none"> • Make sure you have entered the correct code (4 to 8 digits). • Your SIM/USIM card/protected functions will become locked after three unsuccessful attempts. • Contact your SIM/USIM provider if you do not have the correct PIN code.
The SIM/USIM card becomes locked.	<ul style="list-style-type: none"> • Enter the PUK code (8 digits) provided by your service provider (if supported). • If the attempt is successful, enter the new PIN code and confirm your phone is operational again. Otherwise contact your dealer.
The display is difficult to read.	<ul style="list-style-type: none"> • Adjust the backlight brightness for the display.

Problem	Solution
Phone functions do not work after the phone is turned on.	<ul style="list-style-type: none"> • Check the radio signal strength indicator as you may be outside the service area. • Check to see if any error message is displayed when you turn your phone on. If so, contact your dealer. • Make sure the SIM/USIM card is correctly inserted.
Calls cannot be made or received.	<ul style="list-style-type: none"> • If the message “SIM card error” is displayed when the phone is switched on, you cannot use your SIM/USIM card or the SIM/USIM card is damaged. Contact your dealer or network service provider. • Check your call barring, fixed dialling setting, remaining battery and call forwarding settings. • Check if your phone is currently performing data communication using <i>Bluetooth</i> wireless technology interface or a USB data cable. • Check the remaining balance if you are using a pre-paid SIM/USIM card.

Problem	Solution
Call quality is poor.	<ul style="list-style-type: none"> Your current location may not provide good call quality (i.e., in a car or train). Move to a location where radio signal strength is stronger.
Cannot access network service.	<ul style="list-style-type: none"> Check where your account has been registered and where the service is available.
Cannot send or receive text message.	<ul style="list-style-type: none"> Make sure you are correctly subscribed for the Short Message Service, that the network supports this service, and that the centre number is set up correctly. If not, contact your network service provider.
Cannot connect to Multimedia Messaging Service provider.	<ul style="list-style-type: none"> MMS settings and configuration may be missing or incorrect or the network does not support it. Check your service provider's access point number. Contact your service provider to confirm the correct settings.
Limited memory available.	<ul style="list-style-type: none"> Delete any unnecessary data.

Problem	Solution
Call is terminated unexpectedly.	<ul style="list-style-type: none"> Magnetised objects such as health necklaces placed near the phone may terminate the call. Keep your phone away from such objects.
No entries are displayed in the Phonebook.	<ul style="list-style-type: none"> Confirm that the Source setting (Handset or SIM/USIM) is made correctly.
Cannot receive OBEX data.	<ul style="list-style-type: none"> The OBEX data can only be received in standby.

Safety Precautions and Conditions of Use

Your phone conforms to international regulations insofar as it is used under normal conditions and in accordance with the following instructions.

Conditions of Use

Electromagnetic waves

- Do not switch on your phone aboard an aircraft (as your phone may interfere with the aircraft's electronic systems). Current legislation forbids this use and legal action can be taken against the user.
- Do not switch on your phone in a hospital, except in designated areas.
- Use of your phone's function may affect the performance of medical electronic units (pacemakers, hearing aids, insulin pumps, etc.). When the phone function is on, do not bring it near medical equipment or into areas in which medical equipment is being used. If you have a hearing aid or a pacemaker, only use the phone on the opposite side of your body from where it is located. The phone should be kept at least 6 inches (15.24 cm) from a pacemaker ANYTIME the phone is switched on.
- Do not switch on your phone near gas or flammable substances.

- Observe the rules concerning the use of mobile phones at gasoline stations, chemical plants and at all sites where a risk of explosion exists.

Caring for your phone

- Do not allow children to use your phone without supervision.
- Do not open or attempt to repair your phone yourself. The product can only be repaired by authorised service personnel.
- Do not drop your phone or subject it to severe impacts. Bending the body and pushing the display or keys with extreme force could damage the phone.
- Do not use solvents to clean your phone. Use only a soft, dry cloth.
- Do not carry your phone in your back pocket as it could break when you sit down. The display is made of glass and is particularly fragile.
- Avoid touching the external connector on the underside of the phone, since the delicate components within can be damaged by static electricity.

Battery

- Use your phone only with batteries, chargers and accessories recommended by the manufacturer. The manufacturer disclaims any liability for damage caused by the use of other chargers, batteries or accessories.

- **Network configuration and phone usage will affect talk-time and standby time.**

Using the games or camera will hasten battery consumption.

- **When the battery charging alert is displayed on the screen, charge the battery as soon as possible.** If you continue using your phone ignoring the alert, the phone may cease to function, and all data and settings you have stored may be lost at any moment.
- Before removing the battery from the phone, make sure the phone is switched off.
- Replace and charge the new battery as soon as possible after removing the old one.
- Do not touch the battery terminals. Batteries can cause damage, injury or burns if a conductive material touches exposed terminals. When the battery is detached from the phone, use a cover made of non-conductive material for keeping and carrying the battery safely.
- Recommended temperature for using and storing batteries is approximately 20°C.
- The batteries' performance is limited in low temperatures, particularly below 0°C and the phone may not work temporarily regardless of the amount of remaining battery power.
- Exposing the phone to extreme temperatures will shorten battery life.

- The battery can be charged and discharged hundreds of times but it will eventually wear out. When the operating time (talk-time and standby time) is noticeably shorter than normal, it is time to buy a new battery.

CAUTION

RISK OF EXPLOSION IF BATTERY IS REPLACED BY AN INCORRECT TYPE, DISPOSE OF USED BATTERIES ACCORDING TO THE INSTRUCTIONS See "Battery Disposal" on page 12.

Aerial Care

- Do not cover the lower part of the phone (p. 8, No. 18) with your hand when in use as this may interfere with the performance of the built-in aerial. Call quality may deteriorate leading to shortened talk-time and standby time because the mobile phone has to operate on a higher power level than is necessary.
- Use only the aerial supplied or one approved by Sharp for your mobile phone. Using unauthorised or modified aerials may damage the mobile phone. Moreover, since the mobile phone may violate the appropriate regulations, it may lose performance or exceed the limitation of SAR levels.
- To avoid impaired performance, do not damage the aerial of the mobile phone.
- To avoid interfering with blasting operations, please turn off the mobile phone in a blasting area or in a place where a "turn off two-way radio" sign is posted.

Camera Operation

- Learn picture quality, file formats, etc. beforehand.
The taken pictures can be saved in JPEG format.
- Be careful not to move your hand while taking pictures.
If the phone moves while taking a picture, the picture can become blurred. When taking a picture, hold the phone firmly to prevent it from moving, or use the delay timer.
- Clean the lens cover before taking a picture.
Fingerprints, oils, etc. on the lens cover hinder clear focusing. Wipe them off with a soft cloth before taking a picture.

Others

- As with any electronic storage unit, data may be lost or corrupted under various circumstances.
- Before connecting the phone with a PC or a peripheral unit, read the operation manual for the other unit carefully.
- If the phone's battery has been removed for some time, or the phone has been reset, the unit's clock and calendar may be reinitialised. The date and time should be updated in this case.

Environment

- Keep your phone away from extreme heat. Do not leave it on the dashboard of a car or near a heater. Do not leave it in any place that is extremely damp or dusty.
- Since this product is not waterproof, do not use it or store it where fluids such as water can splash onto it. Raindrops, water spray, juice, coffee, steam, perspiration, etc. will also cause malfunctions.

Precautions Concerning Vehicle Use

- It is the user's responsibility to check the local laws governing the use of a mobile phone in vehicles. Pay full attention to driving. Pull off to the side of the road, park the car, and switch off the engine before making or answering a call.
- Use of your phone's function may interfere with the vehicle's electronic systems, such as the ABS anti-lock brakes or the air-bag. To ensure no such problem occurs, please check with your dealer or car manufacturer before connecting your phone.
- Only allow qualified service maintenance personnel to install the vehicle accessories.

The manufacturer disclaims any liability for damage which may result as a consequence of improper use or use contrary to the instructions contained herein.

SAR

Your Sharp mobile phone has been designed, manufactured and tested so as not to exceed the limits for exposure to electromagnetic fields recommended by the Council of the European Union. These limits are part of comprehensive guidelines developed by independent scientific organisations. The guidelines include a substantial safety margin designed to assure the safety of the phone user and others and to take into account variations in age and health, individual sensitivities and environmental conditions. European standards provide for the amount of radio frequency electromagnetic energy absorbed by the body when using a mobile phone to be measured by reference to the Specific Absorption Rate (SAR). The SAR limit for the general public is currently 2 watts per kilogram averaged over 10 grams of body tissue. Your Sharp mobile phone SAR value is 0.512 watts per kilogram. This has been tested to ensure that this limit is not exceeded even when the phone is operating at its highest certified power. In use however your Sharp mobile phone may operate at less than full power because it is designed to use only sufficient power to communicate with the network.

FCC NOTICE

This device complies with part 15 of the FCC Rules.

Operation is subject to the following two conditions:

- (1) This device may not cause harmful interference, and
- (2) this device must accept any interference received, including interference that may cause undesired operation.

Changes or modifications not expressly approved by the manufacturer responsible for compliance could void the user's authority to operate the equipment.

Exposure to Radio Waves

THIS MODEL PHONE MEETS THE GOVERNMENT'S REQUIREMENTS FOR EXPOSURE TO RADIO WAVES.

Your wireless phone is a radio transmitter and receiver. It is designed and manufactured not to exceed the emission limits for exposure to radio frequency (RF) energy set by the Federal Communications Commission of the U.S. Government. These limits are part of comprehensive guidelines and establish permitted levels of RF energy for the general population. The guidelines are based on standards that were developed by independent scientific organizations through periodic and thorough evaluation of scientific studies. The standards include a substantial safety margin designed to assure the safety of all persons, regardless of age and health.

The exposure standard for wireless mobile phones employs a unit of measurement known as the Specific Absorption Rate, or

SAR. The SAR limit set by the FCC is 1.6 W/kg.* Tests for SAR are conducted using standard operating positions specified by the FCC with the phone transmitting at its highest certified power level in all tested frequency bands. Although the SAR is determined at the highest certified power level, the actual SAR level of the phone while operating can be well below the maximum value. This is because the phone is designed to operate at multiple power levels so as to use only the power required to reach the network. In general, the closer you are to a wireless base station antenna, the lower the power output. Before a phone model is available for sale to the public, it must be tested and certified to the FCC that it does not exceed the limit established by the government-adopted requirement for safe exposure. The tests are performed in positions and locations (e.g., at the ear and worn on the body) as required by the FCC for each model. The highest SAR value for this model phone when tested for use at the ear is 0.280 W/kg and when worn on the body, as described in this user guide, is 0.741 W/kg. Body-worn Operation; This device was tested for typical body-worn operations with the back of the phone kept 1.5 cm from the body. To maintain compliance with FCC RF exposure requirements, use accessories that maintain a 1.5 cm separation distance between the user's body and the back of the phone. The use of belt-clips, holsters and similar accessories should not contain metallic components in its assembly.

The use of accessories that do not satisfy these requirements may not comply with FCC RF exposure requirements, and should be avoided. While there may be differences between the SAR levels of various phones and at various positions, they all meet the government requirement for safe exposure.

The FCC has granted an Equipment Authorization for this model phone with all reported SAR levels evaluated as in compliance with the FCC RF emission guidelines. SAR information on this model phone is on file with the FCC and can be found under the Display Grant section of <http://www.fcc.gov/oet/fccid> after searching on FCC ID APYHRO00048.

Additional information on Specific Absorption Rates (SAR) can be found on the Cellular Telecommunications & Internet Association (CTIA) web-site at <http://www.phonefacts.net>.

* In the United States and Canada, the SAR limit for mobile phones used by the public is 1.6 watts/kg (W/kg) averaged over one gram of tissue. The standard incorporates a substantial margin of safety to give additional protection for the public and to account for any variations in measurements.

Out of Warranty List

This limited warranty shall not apply in respect of the following:

- (i) Any deterioration due to normal wear and tear including all plastic surfaces and all other externally exposed parts that are scratched or damaged due to normal customer use.
- (ii) Defects caused by the Product being subjected to any of the following: use in contradiction with the user guide, rough handling, exposure to moisture, dampness or extreme thermal or environmental conditions or rapid changes in such conditions, corrosion, oxidation, unauthorised modifications or connections, unauthorised opening or repair, repair by use of unauthorised spare parts, misuse, improper installation, accident, forces of nature, spillage of food or liquid, influence from chemical products or other acts beyond Sharp's reasonable control (including but not limited to lifetime, and breakage of or damage to antennae) unless the defect was caused directly by defects in materials or workmanship.
- (iii) Products in respect of which the product serial number or the IMEI number has been removed, erased, defaced, altered or made illegible.

- (iv) Defects caused by the fact that the Product was used with or connected to a product or an accessory not manufactured or supplied by Sharp or was used other than for its intended use.
- (v) Defects caused by a defective function of the cellular network.
- (vi) Defects caused by the fact that the battery was short-circuited or seals of the battery enclosure or cells were broken or show evidence of tampering or the battery was used in equipment other than for which it has been specified.
- (vii) Defects caused by the need to upgrade Products software due to changes in cellular network parameters.
- (viii) Products operated outside published maximum ratings.
- (ix) Products rented on a monthly basis.

Charger Plug:

Do not use the AC Charger if the plug does not fit the socket.

Index

Symbols

#/Silent Key 10

* /Shift Key 9

A

Alarms 89

 Resetting 90

 Setting 89

Area Info 62

 Enabling/Disabling 62

B

Battery

 Charging 13

 Disposal 12

 Inserting 11

 Removing 12

Battery Cover 10

Bluetooth 115

 Bluetooth Wireless Function 115

 Bluetooth Wireless Settings 116

Browser 65

Built-in Aerial 10

C

Calculator 90

Calendar 86

 Creating 86

 Deleting 88

 Editing 88

 Receiving 89

 Sending 88

 Viewing a Schedule Entry 87

 Viewing the Memory Status 89

Call Log 114

 Deleting 114

 Sending 114

 Viewing 114

Call Manager 42

 Assigning a Ringtone or a Ring Video

 Clip File 45

 Changing the List 43

 Copying 44

 Creating 43

 Deleting 45

 Dialling 44

 Editing 45

 Finding 43

 Manage Group 46

 Memory Status 47

 Message Groups 46

Receiving 48

Saving 43

Sending a Voice Clip Message or

 Video Clip Message 48

Sending an Entry 48

Sorting the List Order 43

Speed Dial List 47

Viewing My Card 44

Call Settings 106

 Auto Redial 110

 Call Waiting 107

 Changing the Network Password

 109

 Displaying Call Costs 110

 Displaying Call Timer 110

 Fixed Dialling Number 109

 Minute Minder 110

 Rejecting 109

 Restrict Calls 108

 Voicemail & Diverts 106

Call Timers 114

 Checking the Duration 114

 Resetting 114

Camera (photo/video)

 Adjusting the Exposure 50

- Auto Save 51
- Continuous Shoot 53
- Picture Effects 53
- Recording Video Clips 50
- Recording with Sound 55
- Saving 51
- Selecting a Frame 54
- Selecting the Picture or Video Quality 51
- Selecting the Picture Size 52
- Selecting the Recording Time 54
- Selecting the Scene 52
- Selecting the Shutter Sound 54
- Shortcut 52
- Switching between the Photo and Video Camera Modes 51
- Taking Pictures 49
- Using the Full Screen 54
- Using the Timer 51
- Using the Zoom Function 50
- Card Settings 113
 - Formatting Memory Card 113
- Cell Broadcasts 61
 - Enabling/Disabling 61
 - Reading 61
 - Setting Languages 61
 - Subscribing 61
- Centre Key 9, 18
- Characters 32
 - Changing the Input Language 33
 - Changing the Input Method 33
 - Chinese User Dictionary 38
 - Copying, Cutting and Pasting Text 41
 - Insert Phonebook Entries 41
 - Using Templates 41
- Chinese User Dictionary 38
 - Creating 38
 - Deleting 38
 - Editing 38
 - Using 39
- Clear/Back Key 10
- Conditions of Use 126
- Connectivity 115
 - Backup/Restore 121
 - Bluetooth 115
 - Internet Settings 119
 - Network Settings 118
 - Off Line Mode 120
- Countdown Timer 94
 - Editing 95
- D**
- Data Counter 114
 - Resetting 114
- Date & Time 104
 - Customising the Time Zone 104
 - Displaying Date & Time 105
 - Selecting the Date Format 105
 - Selecting the Time Format 105
 - Setting the Calendar Format 105
 - Setting the Daylight Saving 104
 - Setting the Time Zone 104
- Display
 - Adjusting the Brightness 102
 - Assigning the Pictures 101
 - Backlight 102
 - Setting from Picture Gallery 101
 - Setting the Display Saving 103
 - Setting the External Display 103
 - Setting the Greeting Message 102
 - Wallpaper 101
- Display Indicators 18
- E**
- Earpiece 9
- Earpiece Volume 24
- Emergency Calls 22
- End/Power Key 10
- Expenses Memo 95
 - Editing 95
 - Recording 95
 - Viewing Totals 95

- External Camera 10
- External Connector 10
- External Display 10

F

- Functions
 - Navigating 21

G

- Gallery 74
 - Common Option Menus 77
 - Memory Status 80
 - Other Documents 77
 - Picture Gallery 74
 - Sound Gallery 76
 - Text Templates 80
 - Video Gallery 75
- GSX™ & Java™ Gallery 81
 - Deleting 83
 - Downloading 81
 - Executing 81
 - Setting a Screensaver Application 81
 - Setting Network Access 83
 - Setting Permission 82
 - Viewing Application Information 83

H

- Handset Code 112
- Handset Lock 112

- Handsfree Kit
 - Connecting 16
- Handsfree Kit Connector 10

I

- Incall Menu (Video Calling) 28
 - Changing the Image of Yourself 28
 - Muting 28
 - Switching Images 28
 - Turning the Speaker On and Off 28
 - Video Calling Settings 29
- Incall Menu (Voice Call) 24
 - Accessing SMS/MMS Menu 25
 - Call Waiting 25
 - Conference Call 25
 - Earpiece Volume 24
 - Muting 26
 - Putting a Call on Hold 24
 - Turning the Speaker On and Off 24
- International Calls 22

J

- Java™ Information 85
- Java™ Settings 84
 - Application Volume 84
 - Backlight 84
 - Calls & Alarms 85
 - Vibration 84

K

- Keypad 10
- Keypad Lock 17

L

- Language Setting 105
- Left Soft Key 9

M

- Main Display 10
- Master Reset 113
- Media Player 69
 - Music Player 71
 - TV & Video 69
- Memory Card
 - Inserting 14
- Menu 30
- Messages (MMS/SMS/Email)
 - Calling the Phone Number 60
 - Creating 56
 - Downloading 60
 - E-mail Settings 64
 - Forwarding 60
 - General Settings 62
 - Locking or Unlocking 61
 - MMS Settings 64
 - Reading 59
 - Replying 60

- Sending 59
- Sending Options 58
- SMS Settings 63
- Sorting 61
- Storing the Phone Number 59
- Microphone 9
- Music Key 10
- Music Player 71
 - Adding a File to the Playlist 72
 - Adding a New Playlist 73
 - Downloading 73
 - Finding 72
 - Playing Back 71

N

- Navigation Keys 9

O

- Organiser 86
 - Alarms 89
 - Calculator 90
 - Calendar 86
 - Countdown Timer 94
 - Expenses Memo 95
 - Phone Help 95
 - Stopwatch 92
 - Tasks 92
 - Voice Recorder 91

- World Clock 94

P

- PC Connection 122
 - 3G/GSM GPRS Modem 122
 - Handset Manager 123
 - Software Installation 123
 - System Requirements 122
- Picture Gallery 74
 - Adjusting the Size 75
 - Downloading 75
 - Editing 75
 - Saving 74
 - Switching the Memory Source 74
 - Using Images as Wallpaper 74
 - Viewing 74
- Power On and Off 17
- Profiles 97
 - Activating 97
 - Any Key Answer 100
 - Assigning a Ring Video Clip File 98
 - Assigning a Ringtone 98
 - Event Light 100
 - Keypad Tones 99
 - Message Notification 99
 - Resetting 97
 - Ringer Volume 97
 - Status Light 100

- Vibration 99

R

- Redialling 23
- Right Soft Key 10

S

- Safety Precautions 126
- Security 111
 - Changing the PIN2 Code 112
 - Enabling/Disabling the PIN Code 111
 - Function Lock 112
 - Handset Lock 112
 - Showing Secret Data 113
- Send/Redial Key 9
- Set Java™ Wallpaper 83
 - Setting Applications 83
 - Switching On or Off 83
- Side Keys 10
- SIM Application 96
- SIM/USIM Card
 - Inserting 11
 - Removing 12
- Small Light 10
- Sound Gallery 76
 - Playing Back 76
 - Switching the Memory Source 76

- Using the Sound Files as a Ringtone 76
- Speed Dialling 23
- Stopwatch 92
- Sub Camera (Internal Camera) 10

T

- T9 Text Input
 - Using PinYin mode 36
 - Using Stroke mode 36
 - Using T9 English Mode 34
- Tasks
 - Creating 92
 - Deleting 94
 - Sending 93
 - Viewing the Memory Status 94
- Troubleshooting 124
- TV & Video 69
 - Adding a File to the Playlist 69
 - Adding a New Playlist 70
 - Downloading 71
 - Editing 70
 - Finding 69
 - Playing Back 69
 - SD Video 71
 - Settings 70

V

- Video Calling 27
 - Answering 27
 - Incall Menu 28
 - Making 27
- Video Calling Key 9
- Video Calling Settings 110
 - Assigning Hold Guidance Picture 111
 - Backlight 111
 - Muting 111
 - Selecting an Image 110
 - Selecting Picture Quality 110
 - Turning On or Off the Speakers 110
- Video Gallery 75
 - Downloading 76
 - Playing Back 75
 - Using a Video Clip as a Ring Video 76
- Voice Call 22
 - Answering 23
 - Incall Menu 24
 - Making 22
 - Redialling 23
 - Speed Dialling 23
- Voice Mail Key 9
- Voice Recorder 91
 - Recording 91
 - Saving 92

- Selecting the Record Time 92
- Sending 91

Voice Recorder Key 10

W

- WAP Browser
 - Browser Options 67
 - Editing Bookmarks 66
 - Main Menu 65
 - Navigating a WAP Page 66
 - Settings 68
- World Clock 94
 - Setting the Daylight Saving 94
 - Setting the Time Zone 94